



GANESH INSTITUTE OF ENGINEERING AND TECHNOLOGY (GIET),  
Jagannath Prasad, Andharua, BHUBANESWAR

# Control System Engineering (Th- 03)

(As per the 2019-20 syllabus of the SCTE&VT,  
Bhubaneswar, Odisha)



sixth Semester

Electrical Engg.

**Prepared By:** Er. P .K .DASH

## SUB :CONTROLSYSTEM ENGINEERING(Th 3)

### Learning Resources:

Sl.No	Title of the Book	Name of Author	Publishers
1.	Control system	A.Ananda kumar	PHI
2.	Control system	k. padmanavan	IK
3	Control system Engineering	I.J.Nagarath,M.Gopal	WEN
4	Control system engineering	ANatraj ,Ramesh Babu	SCIENTIFIC

### TOPIC WISE DISTRIBUTION PERIODS

Sl. No	Chapter	Topic	Periods as per syllabus	Periods Actually needed	Expected marks
01	01	Fundamental of control system	04	04	05
02	02	Mathematical model of a system	04	05	10
03	03	Control system components	04	04	05
04	04	Block diagram algebra &Signal flow graph	08	09	15
05	05	Time response Analysis	10	11	15
06	06	Analysis of stability By Root Locus Technique	10	07	20
07	07	Frequency response Analysis	10	07	15
08	08	Nyquist Plot	10	07	15
		<b>TOTAL</b>	<b>60</b>	<b>54</b>	<b>100</b>

## CHAPTER-1

### FUNDAMENTAL OF CONTROL SYSTEM

#### INTRODUCTION

A control system is an arrangement of physical components connected or related in such a manner as to command, direct, or regulate itself or another system, or is that means by which any quantity of interest in a system is maintained or altered in accordance with a desired manner.

Any control system consists of three essential components namely input, system and output. The input is the stimulus or excitation applied to a system from an external energy source. A system is the arrangement of physical components and output is the actual response obtained from the system. The control system may be one of the following type.

- 1) man made
- 2) natural and / or biological and
- 3) hybrid consisting of man made and natural or biological.

Examples:

- 1) An electric switch is man made control system, controlling flow of electricity. input : flipping the switch on/off  
system : electric switch  
output : flow or no flow of current
- 2) Pointing a finger at an object is a biological control system.  
input : direction of the object with respect to some direction  
system : consists of eyes, arm, hand, finger and brain of a man  
output : actual pointed direction with respect to same direction
- 3) Man driving an automobile is a hybrid system. input : direction or lane  
system : drivers hand, eyes, brain and vehicle  
output : heading of the automobile.

#### 1.1 Classification of Control Systems

Control systems are classified into two general categories based upon the control action which is responsible to activate the system to produce the output viz.

- 1) Open loop control system in which the control action is independent of the output.
- 2) Closed loop control system in which the control action is some how dependent upon the output and are generally called as feedback control systems.

- 3)
- 4) **1.2 :Open Loop System: It** is a system in which control action is independent of output. To each reference input there is a corresponding output which depends upon the system and its operating conditions. The accuracy of the system depends on the calibration of the system. In the presence of noise or disturbances open loop control will not perform satisfactorily.
- 5)
- 6)
- 7)

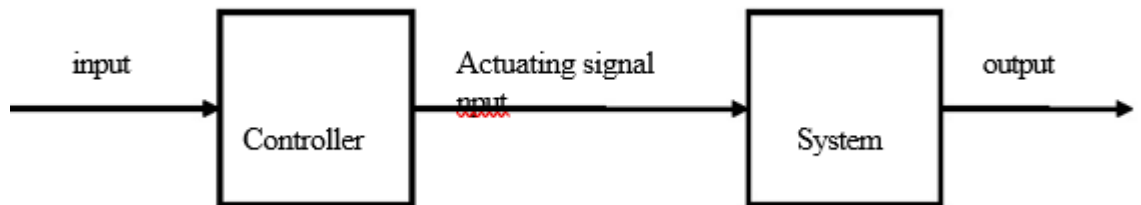

8) EXAMPLE - 1 Rotational Generator

9)

10) The input to rotational generator is the speed of the prime mover ( e.g steam turbine) in r.p.m. Assuming the generator is on no load the output may be induced voltage at the output terminals

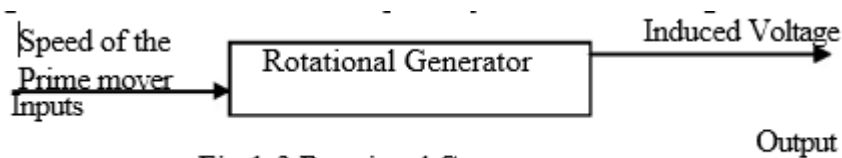

Fig 1-2 Rotational Generator

11) EXAMPLE - 2 Washing machine

12) Most ( but not all ) washing machines are operated in the following manner. After the clothes to be washed have been put into the machine, the soap or detergent, bleach and water are entered in proper amounts as specified by the manufacturer. The washing time is then set on a timer and the washer is energized. When the cycle is completed, the machine shuts itself off. In this example washing time forms input and cleanliness of the clothes is identified as output.

13)

14)

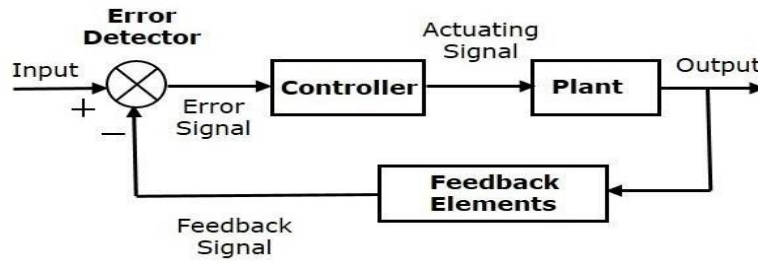

Fig 1-3 Washing Machine

**15) Close Loop**

16) In **closed loop control systems**, output is fed back to the input. So, the control action is dependent on the desired output.

The following figure shows the block diagram of negative feedback closed loop control system.



The error detector produces an error signal, which is the difference between the input and the feedback signal. This feedback signal is obtained from the block (feedback elements) by considering the output of the overall system as an input to this block. Instead of the direct input, the error signal is applied as an input to a controller.

So, the controller produces an actuating signal which controls the plant. In this combination, the output of the control system is adjusted automatically till we get the desired response. Hence, the closed loop control systems are also called the automatic control systems. Traffic lights control system having sensor at the input is an example of a closed loop control system.

**The differences between the open loop and the closed loop control systems are mentioned in the following tab**

Open Loop Control Systems	Closed Loop Control Systems
Control action is independent of the desired output.	Control action is dependent of the desired output.
Feedback path is not present.	Feedback path is present.
These are also called as non-feedback control systems.	These are also called as feedback control systems.
Easy to design.	Difficult to design.
These are economical.	These are costlier.
Inaccurate.	Accurate.

## Control Systems - Feedback

If either the output or some part of the output is returned to the input side and utilized as part of the system input, then it is known as **feedback**. Feedback plays an important role in order to improve the performance of the control systems. In this chapter, let us discuss the types of feedback & effects of feedback.

### Types of Feedback

There are two types of feedback –

- Positive feedback
- Negative feedback

### Positive Feedback

The positive feedback adds the reference input,  $R(s)$  and feedback output. The following figure shows the block diagram of **positive feedback control system**.

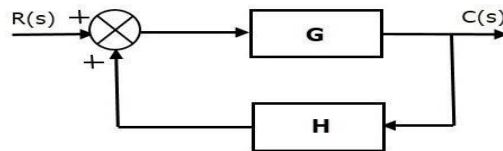

The concept of transfer function will be discussed in later chapters. For the time being, consider the transfer function of positive feedback control system is,

$$T = \frac{G}{1-GH} \quad (\text{Equation 1})$$

Where,

- **T** is the transfer function or overall gain of negative feedback control system.
- **G** is the open loop gain, which is function of frequency.
- **H** is the gain of feedback path, which is function of frequency.

### Negative Feedback

Negative feedback reduces the error between the reference input,  $R(s)$  and system output. The following figure shows the block diagram of the **negative feedback control system**.

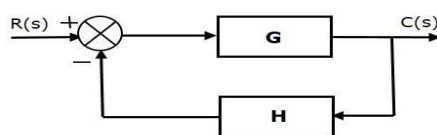

Transfer function of negative feedback control system is,

$$T = \frac{G}{1+GH} \quad \text{(Equation 2)}$$

Where,

- **T** is the transfer function or overall gain of negative feedback control system.
- **G** is the open loop gain, which is function of frequency.
- **H** is the gain of feedback path, which is function of frequency.

### 1.3:Effects of Feedback

Let us now understand the effects of feedback.

Effect of Feedback on Overall Gain

- From Equation 2, we can say that the overall gain of negative feedback closed loop control system is the ratio of 'G' and (1+GH). So, the overall gain may increase or decrease depending on the value of (1+GH).
- If the value of (1+GH) is less than 1, then the overall gain increases. In this case, 'GH' value is negative because the gain of the feedback path is negative.
- If the value of (1+GH) is greater than 1, then the overall gain decreases. In this case, 'GH' value is positive because the gain of the feedback path is positive.

In general, 'G' and 'H' are functions of frequency. So, the feedback will increase the overall gain of the system in one frequency range and decrease in the other frequency range.

### 1.4:Standard Test Signals

The standard test signals are impulse, step, ramp and parabolic. These signals are used to know the performance of the control systems using time response of the output.

#### Step function

A unit step signal,  $u(t)$  is defined as

$$u(t)=1; t \geq 0$$

$$u(t)=0; t < 0$$

Following figure shows unit step signal.

## Step function

A unit step signal,  $u(t)$  is defined as

$$u(t)=1; t \geq 0$$

$$u(t)=0; t < 0$$

Following figure shows unit step signal.

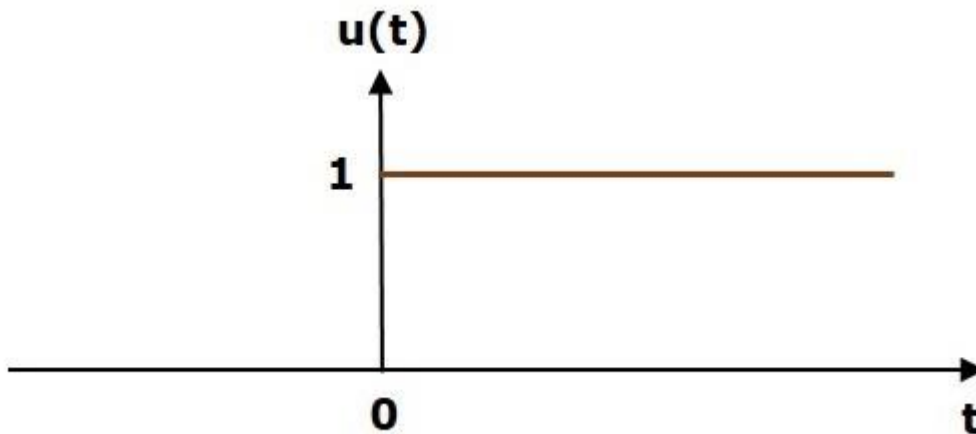

So, the unit step function exists for all positive values of 't' including zero. And its value is one during this interval. The value of the unit step signal is zero for all negative values of 't'.

## Unit Ramp function

A unit ramp signal,  $r(t)$  is defined as

$$r(t)=t; t \geq 0$$

$$r(t)=0; t < 0$$

We can write unit ramp function,  $r(t)$  in terms of unit step signal,  $u(t)$  as

$$r(t)=tu(t)$$

Following figure shows unit ramp signal.

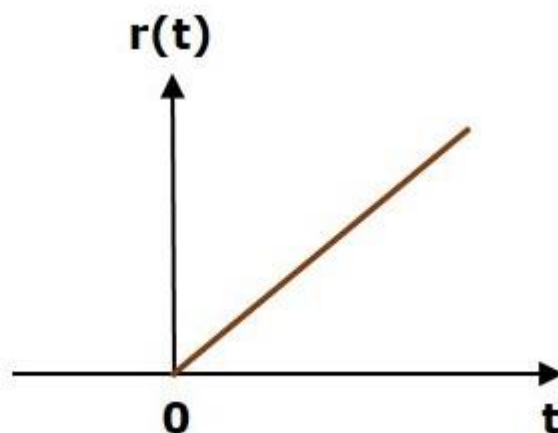

So, the unit ramp signal exists for all positive values of 't' including zero. And its value increases linearly with respect to 't' during this interval. The value of unit ramp signal is zero for all negative values of 't'.

### Parabolic function

A unit parabolic signal, p(t) is defined as,

$$p(t)=t^2/2; t \geq 0$$

$$p(t)=0; t < 0$$

We can write unit parabolic function, p(t) in terms of the unit step signal, u(t) as,

$$p(t)= p^2/2 u(t)$$

The following figure shows the unit parabolic signal.

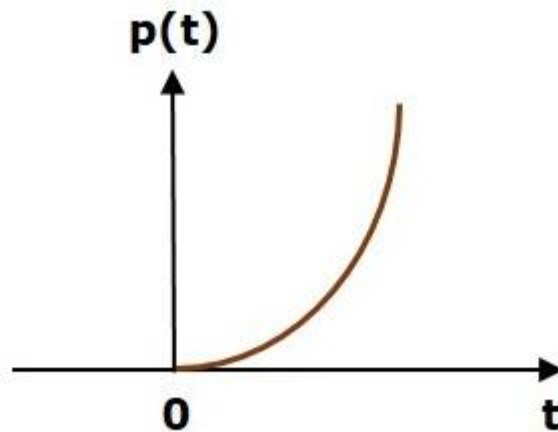

So, the unit parabolic signal exists for all the positive values of 't' including zero. And its value increases non-linearly with respect to 't' during this interval. The value of the unit parabolic signal is zero for all the negative values of 't'.

### Unit Impulse Signal

A unit impulse signal,  $\delta(t)$  is defined as

$$\delta(t)=0 \delta(t)=0 \text{ for } t \neq 0$$

$$\text{and } \int_{0+0-} \delta(t) dt = 1$$

The following figure shows unit impulse signal.

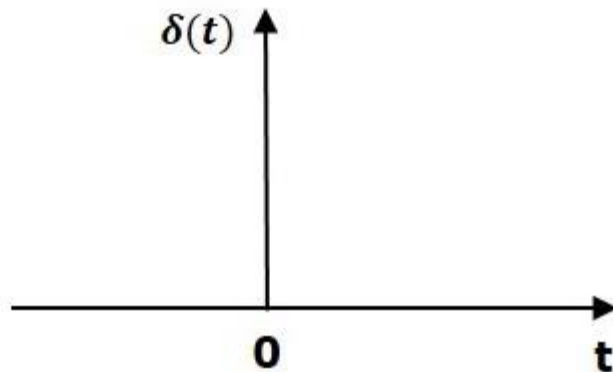

So, the unit impulse signal exists only at 't' is equal to zero. The area of this signal under small interval of time around 't' is equal to zero is one. The value of unit impulse signal is zero for all other values of 't'.

## 1.5: Servomechanism

### Servomechanism

A servo system primarily consists of three basic components – a controlled device, a output sensor, a feedback system.

This is an automatic closed loop control system. Here instead of controlling a device by applying the variable input signal, the device is controlled by a feedback signal generated by comparing output signal and reference input signal.

When reference input signal or command signal is applied to the system, it is compared with output reference signal of the system produced by output sensor, and a third signal produced by a feedback system. This third signal acts as an input signal of controlled device.

This input signal to the device presents as long as there is a logical difference between reference input signal and the output signal of the system.

After the device achieves its desired output, there will be no longer the logical difference between reference input signal and reference output signal of the system. Then, the third signal produced by comparing theses above said signals will not remain enough to operate the device further and to produce a further output of the system until the next reference input signal or command signal is applied to the system.

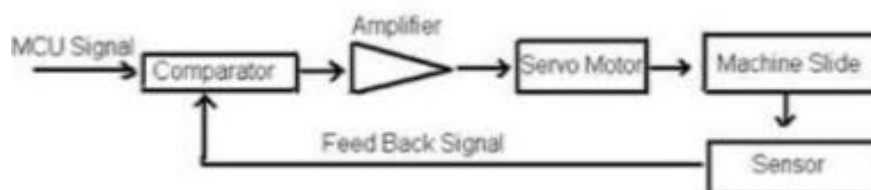

### Short questions

1: Name three applications of control systems. Ans: Guided missiles, Fighter plane stability, Satellite tracking antenna

2 What is meant by System?

When the number of elements connected performs a specific function then the group of elements is said to constitute a system or interconnection of various components for a specific task is called system. Example: Automobile.

3 What is meant by Control System?

Any set of mechanical or electronic devices that manages, regulates or commands the behavior of the system using control loop is called the Control System. It can range from a small controlling device to a large industrial controlling device which is used for controlling processes or machines.

3 What is open loop and control loop systems?

Open loop control System: An open-loop control system is a system in which the control action is independent of the desired output signal. Examples: Automatic washing machine, Immersion rod.

Closed loop control System: A closed-loop control system is a system in which control action is dependent on the desired output. Examples: Automatic electric iron, Servo voltage stabilizer, an air conditioner.

4 What are the necessary components of the feedback control system?

The processing system (open loop system), feedback path element, an error detector, and controller are the necessary components of the feedback control system.

5 What is the feedback in the control system?

When the input is fed to the system and the output received is sampled, and the proportional signal is then fed back to the input for automatic correction of the error for further processing to get the desired output is called as feedback in control system

### Long Questions

1: What are the advantages and disadvantages of open loop control System?

2: What are the advantages and disadvantages of closed-loop control System?

3: Name the three major design criteria for control systems.

## Chapter-2

### Mathematical model of a System

The control systems can be represented with a set of mathematical equations known as **mathematical model**. These models are useful for analysis and design of control systems. Analysis of control system means finding the output when we know the input and mathematical model. Design of control system means finding the mathematical model when we know the input and the output.

The following mathematical models are mostly used.

- Differential equation model
- Transfer function model

## • Transfer Function Model

- Transfer function model is an s-domain mathematical model of control systems. The **Transfer function** of a Linear Time Invariant (LTI) system is defined as the ratio of Laplace transform of output and Laplace transform of input by assuming all the initial conditions are zero.
- If  $x(t)$  and  $y(t)$  are the input and output of an LTI system, then the corresponding Laplace transforms are  $X(s)$  and  $Y(s)$ .
- Therefore, the transfer function of LTI system is equal to the ratio of  $Y(s)$  and  $X(s)$ . *i.e.*,  $\text{TransferFunction} = Y(s)/X(s)$
- The transfer function model of an LTI system is shown in the following figure.
- 

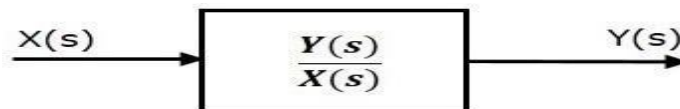

- 
- Here, we represented an LTI system with a block having transfer function inside it. And this block has an input  $X(s)$  & output  $Y(s)$ .
- 

The transfer function of a control system is defined as the ratio of the Laplace transform of the output variable to Laplace transform of the input variable assuming all initial conditions to be zero.

Thus the cause and effect relationship between the output and input is related to each other through a **transfer function**.



In a Laplace Transform, if the input is represented by  $R(s)$  and the output is represented by  $C(s)$ , then the transfer function will be:

$$G(s) = \frac{C(s)}{R(s)} \Rightarrow R(s).G(s) = C(s)$$

That is, the transfer function of the system multiplied by the input function gives the output function of the system.

$$G(s) = \frac{C(s)}{R(s)}$$

## The Effect of Impulse Signal

The unit impulse signal is defined as

$$\begin{aligned} \delta(t) &= 1 \text{ when } t = 0 \\ &= 0 \text{ when } t \neq 0 \end{aligned}$$

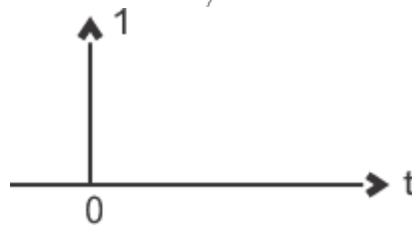

Laplace transform of unit impulse function is 1.

$$\mathcal{L}\delta(t) = 1$$

Now if input signal is unit impulse signal then,

$$\frac{C(s)}{R(s)} = G(s) \Rightarrow C(s) = R(s)G(s) \Rightarrow C(s) = G(s)$$

$$[\because \mathcal{L}\delta(t) = 1]$$

The output function is same as its transfer function.

## PROPERTIES OF TRANSFER FUNCTION (TF)

The properties of transfer function are given below:

- The ratio of Laplace transform of output to Laplace transform of input assuming all initial conditions to be zero.
- The transfer function of a system is the Laplace transform of its impulse response under assumption of zero initial conditions.

$$D \equiv \frac{d}{dt}$$

- Replacing 's' variable with linear operation  $\frac{d}{dt}$  in transfer function of a system, the differential equation of the system can be obtained.
- The transfer function of a system does not depend on the inputs to the system.
- The system poles and zeros can be determined from its transfer function.
- Stability can be found from ...characteristics equations.

### Advantages of Transfer function

1. If transfer function of a system is known, the response of the system to any input can be determined very easily.
2. A transfer function is a mathematical model and it gives the gain of the system.
3. Since it involves the Laplace transform, the terms are simple algebraic expressions and no differential terms are present.
4. Poles and zeroes of a system can be determined from the knowledge of the transfer function of the system.

### Disadvantages of Transfer function

1. Transfer function does not take into account the initial conditions.
2. The transfer function can be defined for linear systems only.
3. No inferences can be drawn about the physical structure of the system.

### Poles and Zeros of Transfer Function

Generally, a function can be represented to its polynomial form. For example,

$$F(s) = f_0s^n + f_1s^{n-1} + f_2s^{n-2} + f_3s^{n-3} + \dots + f_{n-1}s^1 + f_n$$

Now similarly transfer function of a control system can also be represented as

$$G(s) = \frac{C(s)}{R(s)} = \frac{C_0s^n + C_1s^{n-1} + C_2s^{n-2} + \dots + C_{n-1}s + C_n}{R_0s^m + R_1s^{m-1} + R_2s^{m-2} + \dots + R_{m-1}s + R_m}$$

$$= K \frac{(s - z_1)(s - z_2)(s - z_3) \dots (s - z_n)}{(s - p_1)(s - p_2)(s - p_3) \dots (s - p_m)}$$

Where K is known as the gain factor of the transfer function.

Now in the above function if  $s = z_1$ , or  $s = z_2$ , or  $s = z_3, \dots, s = z_n$ , the value of transfer function becomes zero. These  $z_1, z_2, z_3, \dots, z_n$ , are roots of the numerator polynomial. As for these roots the numerator polynomial, the transfer function becomes zero, these roots are called zeros of the transfer function.

Now, if  $s = p_1$ , or  $s = p_2$ , or  $s = p_3, \dots, s = p_m$ , the value of transfer function becomes infinite. Thus the roots of denominator are called the poles of the function.

Now let us rewrite the transfer function in its polynomial form.

$$G(s) = K \frac{(s - z_1)(s - z_2)(s - z_3) \cdots (s - z_n)}{(s - p_1)(s - p_2)(s - p_3) \cdots (s - p_m)}$$

Now, let us consider  $s$  approaches to infinity as the roots are all finite number, they can be ignored compared to the infinite  $s$ . Therefore

$$G(s) = K \frac{s^n}{s^m} = K s^{n-m}$$

Hence, when  $s \rightarrow \infty$  and  $n > m$ , the function will have also value of infinity, that means the transfer function has poles at infinite  $s$ , and the multiplicity or order of such pole is  $n - m$ .

Again, when  $s \rightarrow \infty$  and  $n < m$ , the transfer function will have value of zero that means the transfer function has zeros at infinite  $s$ , and the multiplicity or order of such zeros is  $m - n$ .

- 1) Let us explain the concept of poles and zeros of transfer function through an example.

$$G(s) = \frac{(s + 1)(s + 2)}{(s + 3)(s + 4)(s + 5)(s + 2 - 4j)(s + 2 + 4j)}$$

Solution

The zeros of the function are, -1, -2 and the poles of the functions are -3, -4, -5, -2 + 4j, -2 - 4j.

- 2) Here  $n = 2$  and  $m = 5$ , as  $n < m$  and  $m - n = 3$ , the function will have 3 zeros at  $s \rightarrow \infty$ . The poles and zeros are plotted in the figure below

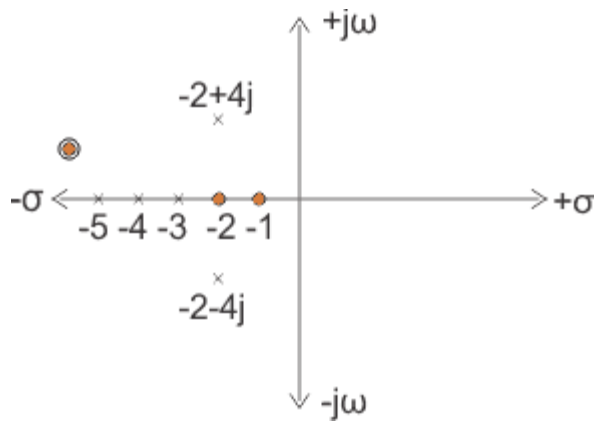

2) Let us take another example of transfer function of control system

$$G(s) = \frac{(s - 2)(s + 5)(s + 8)}{s(s + 1)(s + 6)(s + 9)(s + 1 - j3)(s + 1 + j3)}$$

## Solution

In the above transfer function, if the value of numerator is zero, then

$$(s - 2)(s + 5)(s + 8) = 0$$

$$\Rightarrow s = 2, -5, -8$$

These are the location of zeros of the function.

Similarly, in the above transfer function, if the value of denominator is zero, then

$$s(s + 1)(s + 6)(s + 9)(s + 1 - j3)(s + 1 + j3) = 0$$

$$\Rightarrow s = 0, -1, -6, -9, -1 + j3, -1 - j3$$

These are the location of poles of the function.

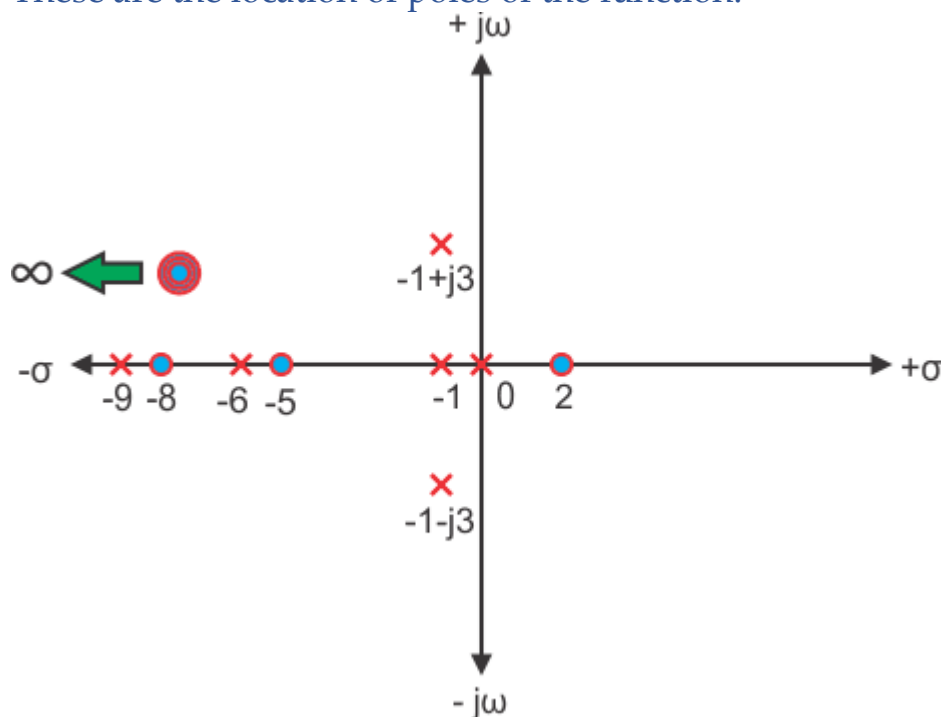

As the number of zeros should be equal to number of poles, the remaining three zeros are located at  $s \rightarrow \infty$ .

## Mathematical Modelling of Electrical System

In an electrical type of system we have three variables –

1. Voltage which is represented by 'V'.
2. Current which is represented by 'I'.
3. Charge which is represented by 'Q'.

And also we have three parameters which are active and passive components:

1. Resistance which is represented by 'R'.
2. Capacitance which is represented by 'C'.
3. Inductance which is represented by 'L'.

Now we are in condition to derive analogy between electrical and mechanical types of systems. There are two types of analogies and they are written below:

Force Voltage Analogy : In order to understand this type of analogy, let us consider a circuit which consists of series combination of resistor, inductor and capacitor.

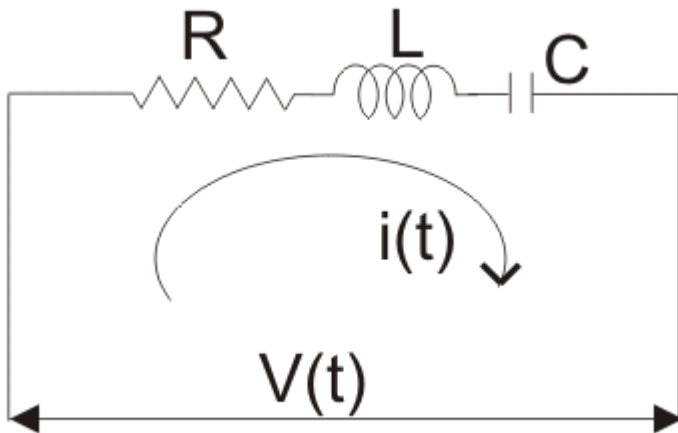

A voltage  $V$  is connected in series with these elements as shown in the circuit diagram. Now from the circuit diagram and with the help of KVL equation we write the expression for voltage in terms of charge, resistance, capacitor and inductor as,

$$V = L \frac{d^2q}{dt^2} + R \frac{dq}{dt} + \frac{q}{C}$$

### CHAPTER-3 CONTROL SYSTEM COMPONENTS

#### 3.1:component of control system

Transducer which is the first major component in a control system is a device that senses the output in one form and convert it into another form,the sensing may be temperature,pressure,position,and conversion is generally into electrical

#### 3.2 :Gyroscope

**It is an** instrument used in space ships and aircrafts .The input is the angular velocity and the out put is the angular displacement.The action of gyroscope is is based on following principles.

1. If no external torque acts on it the spinning wheel maintains the direction of its spin axis in space and this type of spinning is known as free gyrotpe
2. If torque is applied to an axis inclined to the spin axis of a wheel the wheel rotate about an axis at an angle  $90^0$  to both the spin axis as well as the input torque axis .this type of rotation is known as precision type

## Synchro

**Definition:** The Synchro is a **type of transducer** which **transforms** the **angular position of the shaft** into an **electric signal**. It is used as an **error detector** and as a **rotary position sensor**. The error occurs in the system because of the misalignment of the shaft. The transmitter and the control [transformer](#) are the two main parts of the synchr

### Synchros System Types

The synchro system is of two types. They are

1. Control Type Synchro.
2. Torque Transmission Type Synchro.

### Torque Transmission Type Synchros

This type of synchros has small output torque, and hence they are used for running the very light load like a pointer. The control type Synchro is used for driving the large loads.

### Control Type Synchros System

The controls synchros is used for error detection in positional control systems. Their systems consist two units. They are

1. Synchro Transmitter
2. Synchro receiver
3. The synchro always works with these two parts. The detail explanation of synchros transmitter and receiver is given below.
4. **Synchros Transmitter** – Their construction is similar to the three phase alternator. The stator of the synchros is made of steel for reducing the iron losses. The stator is slotted for housing the three phase windings. The axis of the stator winding is kept  $120^\circ$  apart from each other.

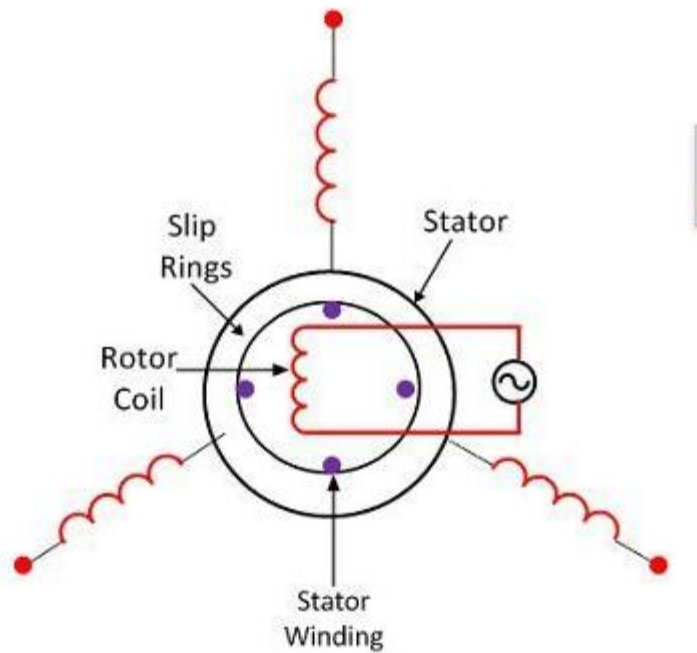

Constructional Feature of Synchronos Transmitter

Circuit Globe |

#

The AC voltage is applied to the rotor of the transmitter and it is expressed as

Where  $V_r$  – r.ms.value of rotor voltage

$\omega_c$  – carrier frequency

The coils of the stator windings are connected in star. The rotor of the synchronos is a dumbbell in shape, and a concentric coil is wound on it. The AC voltage is applied to the rotor with the hel constructional feature of the synchronos is shown in the figure below.

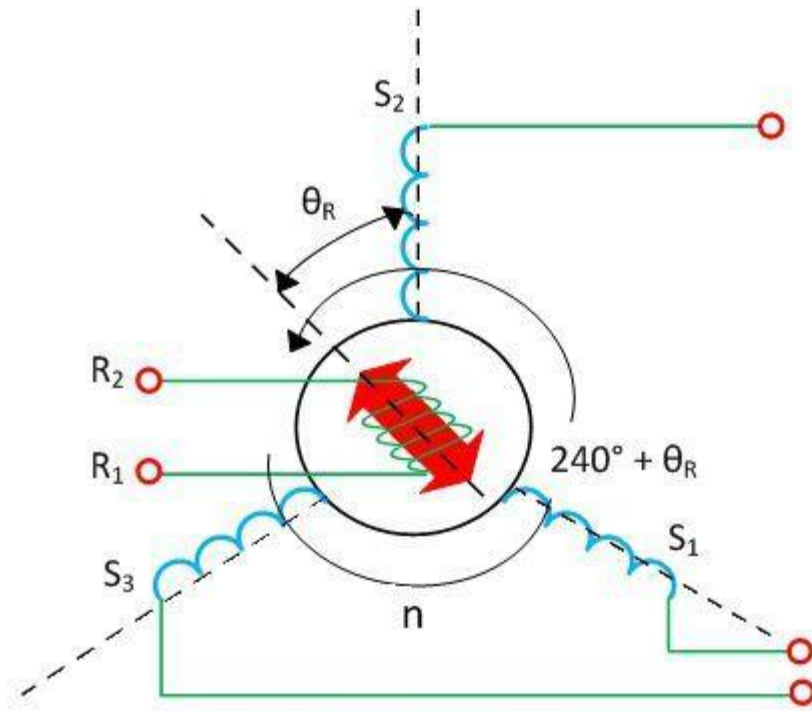

**Sychro Transmitter**

Circuit-Globe

Consider the voltage is applied to the rotor of the transmitter as shown in the figure

**sychro r transmitter**

Circuit Globe

Consider the voltage is applied to the rotor of the transmitter as shown in the figure

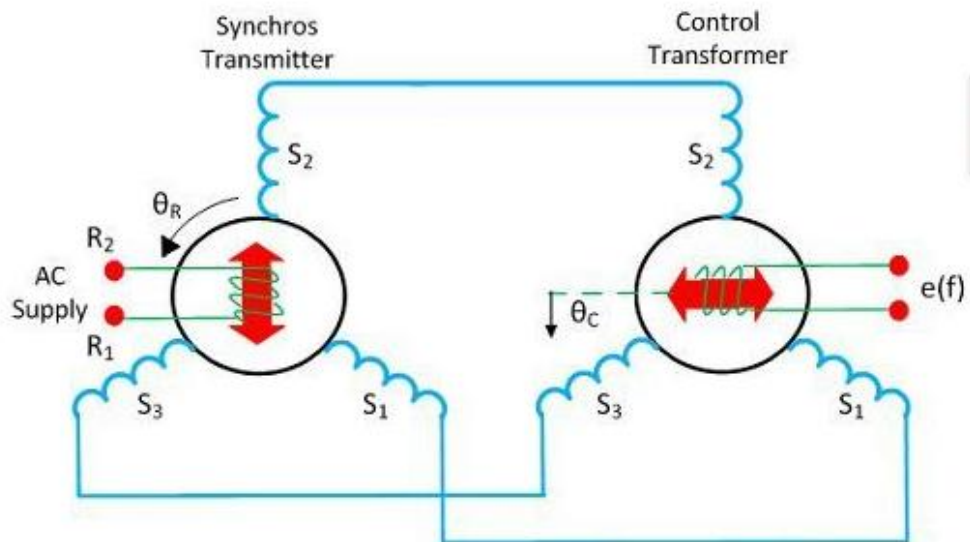

<https://cuploads, Ctrl+Click>

**Syncho Error Dectector**

Circuit Globe

The voltage applied to the rotor induces the magnetizing current and an alternating flux along its axis. The voltage is induced in the stator winding because of the mutual induction between the rotor and stator flux. The flux linked in the stator winding is equal to the cosine of the angle between the rotor and stator. The voltage is induced in the stator winding.

Let  $V_{s1}$ ,  $V_{s2}$ ,  $V_{s3}$  be the voltages generated in the stator windings  $S_1$ ,  $S_2$ , and  $S_3$  respectively. The figure below shows the rotor position of the synchro transmitter. The rotor axis makes an angle

$$V_{s1n} = kV_r \sin \omega_c t \cos(\theta_R + 120^\circ)$$

$$V_{s2n} = kV_r \sin \omega_c t \cos \theta_R$$

$$V_{s3n} = kV_r \sin \omega_c t \cos(\theta_R + 240^\circ)$$

$\theta_r$  concerning the stator windings  $S_2$ .

$$V_{s1s2} = V_{s1n} - V_{s2n}$$

$$V_{s1s2} = \sqrt{3}kV_r \sin(\theta_R + 240^\circ) \sin \omega_c t$$

$$V_{s3s2} = V_{s2n} - V_{s3n}$$

$$V_{s1s2} = \sqrt{3}kV_r \sin(\theta_R + 120^\circ) \sin \omega_c t$$

$$V_{s3s1} = V_{s3n} - V_{s1n}$$

$$V_{s3s1} = kV_r \sin \omega_c t \sin \theta_R$$

The three terminals of the stator windings are

The variation in the stator terminal axis concerning the rotor is shown in the figure below.

$$e(t) = k'V_r \cos(90^\circ - \theta_R + \theta_C) \sin \omega_c t$$

$$e(t) = k'V_r \sin(\theta_R - \theta_C) \sin \omega_c t$$

When the rotor angle becomes zero, the maximum current is produced in the stator windings  $S_2$ . The zero position of the rotor is used as a reference for determining the rotor angular position.

The output of the transmitter is given to stator winding of the control transformer which is shown in the above figure.

The current of the same and magnitude flow through the transmitter and control transformer of the synchros. Because of the circulating current, the flux is established between the air gap flux of the control transformer.

The flux axis of the control transformer and the transmitter is aligned in the same position. The voltage generated by the rotor of control transformer is equal to the cosine of the angle between the rotors of the transmitter and the controller. The voltage is given as  $e(t) = k'V_r \cos\phi \sin\omega_c t$

The voltage applied to the rotor induces the magnetizing current and an alternating flux along its axis. The voltage is induced in the stator winding because of the mutual induction between the rotor and stator flux. The flux linked in the stator winding is equal to the cosine of the angle between the rotor and stator. The voltage is induced in the stator winding.

Let  $V_{s1}$ ,  $V_{s2}$ ,  $V_{s3}$  be the voltages generated in the stator windings  $S_1$ ,  $S_2$ , and  $S_3$  respectively. The figure below shows the rotor position of the synchro transmitter. The rotor axis makes an angle

$$V_{s1n} = kV_r \sin\omega_c t \cos(\theta_R + 120^\circ)$$

$$V_{s2n} = kV_r \sin\omega_c t \cos\theta_R$$

$$V_{s3n} = kV_r \sin\omega_c t \cos(\theta_R + 240^\circ)$$

$\theta_r$  concerning the stator windings  $S_2$ .

$$V_{s1s2} = V_{s1n} - V_{s2n}$$

$$V_{s1s2} = \sqrt{3}kV_r \sin(\theta_R + 240^\circ) \sin\omega_c t$$

$$V_{s3s2} = V_{s2n} - V_{s3n}$$

$$V_{s1s2} = \sqrt{3}kV_r \sin(\theta_R + 120^\circ) \sin\omega_c t$$

$$V_{s3s1} = V_{s3n} - V_{s1n}$$

$$V_{s3s1} = kV_r \sin\omega_c t \sin\theta_R$$

5. The three terminals of the stator windings are

The variation in the stator terminal axis concerning the rotor is shown in the figure below.

$$e(t) = k'V_r \cos(90^\circ - \theta_R + \theta_C) \sin\omega_c t$$

$$e(t) = k'V_r \sin(\theta_R - \theta_C) \sin\omega_c t$$

When the rotor angle becomes zero, the maximum current is produced in the stator windings  $S_2$ . The zero position of the rotor is used as a reference for determining the rotor angular position.

The output of the transmitter is given to stator winding of the control transformer which is shown in the above figure.

The current of the same and magnitude flow through the transmitter and control transformer of the synchros. Because of the circulating current, the flux is established between the air gap flux

of the control transformer.

The flux axis of the control transformer and the transmitter is aligned in the same position. The voltage generated by the rotor of control transformer is equal to the cosine of the angle between the rotors of the transmitter and the controller. The voltage is given as

$$e(t) = k'V_r \cos\phi \sin\omega_c t$$

Where  $\phi$  – angular displacement between the rotor axes of transmitter and controller.

Where  $\phi$  – angular displacement between the rotor axes of transmitter and controller.

$\Phi = 90^\circ$  the axis between the rotor of transmitter and control transformer is perpendicular to each other. The above figure shows the zero position of the rotor of transmitter and receiver.

Consider the position of the rotor and the transmitter is changing in the same direction. An angle  $\theta_R$  deflects the rotor of the transmitter and that of the control transformer is kept  $\theta_C$ . The total angular separation between the rotors is  $\Phi = (90^\circ - \theta_R + \theta_C)$

The rotor terminal voltage of the Synchro transformer is given as

$$e(t) = k'V_r \cos(90^\circ - \theta_R + \theta_C) \sin\omega_c t$$

$$e(t) = k'V_r \sin(\theta_R - \theta_C) \sin\omega_c t$$

The small angular displacement between their rotor

position is given as

$$\sin(\theta_R - \theta_C) = (\theta_R - \theta_C)$$

On substituting the value of angular displacement in equation (1) we get

$$e(t) = k'V_r \cos\phi \sin\omega_c t$$

The synchro transmitter and the control transformer together used for detecting the error. The voltage equation shown above is equal to the shaft position of the rotors of control transformer and transmitter.

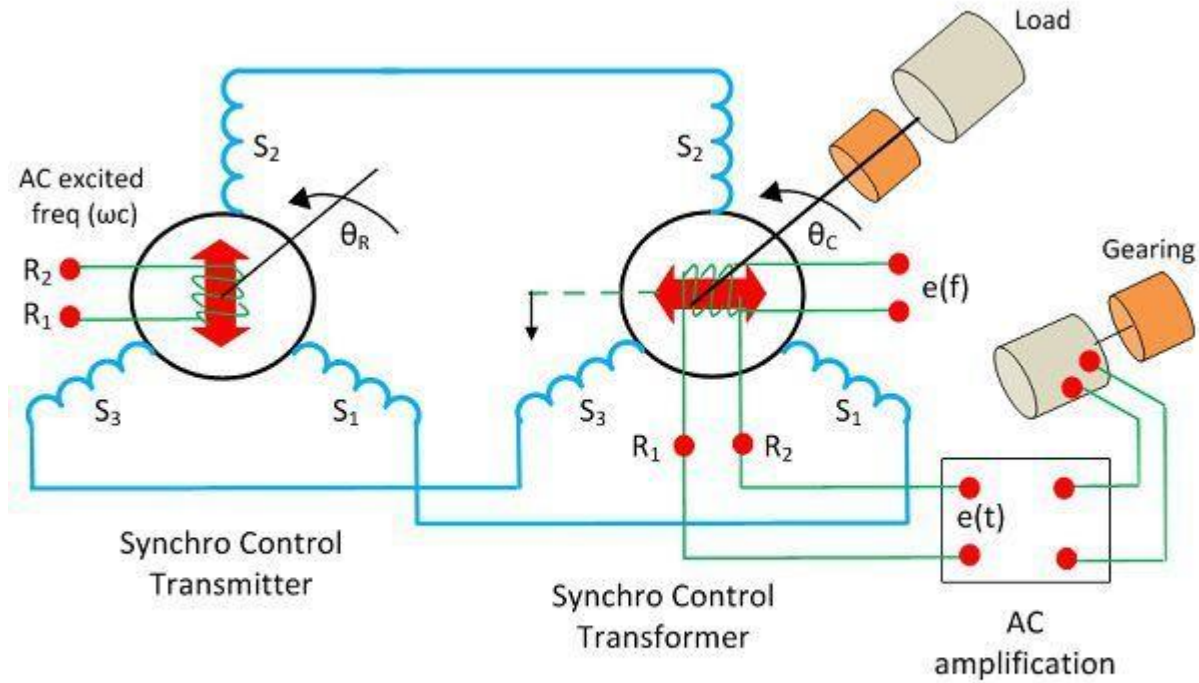

## Positional Control System

The error signal is applied to the differential amplifier which gives input to the servo motor. The gear of the servo motor rotates the rotor of the control transformer

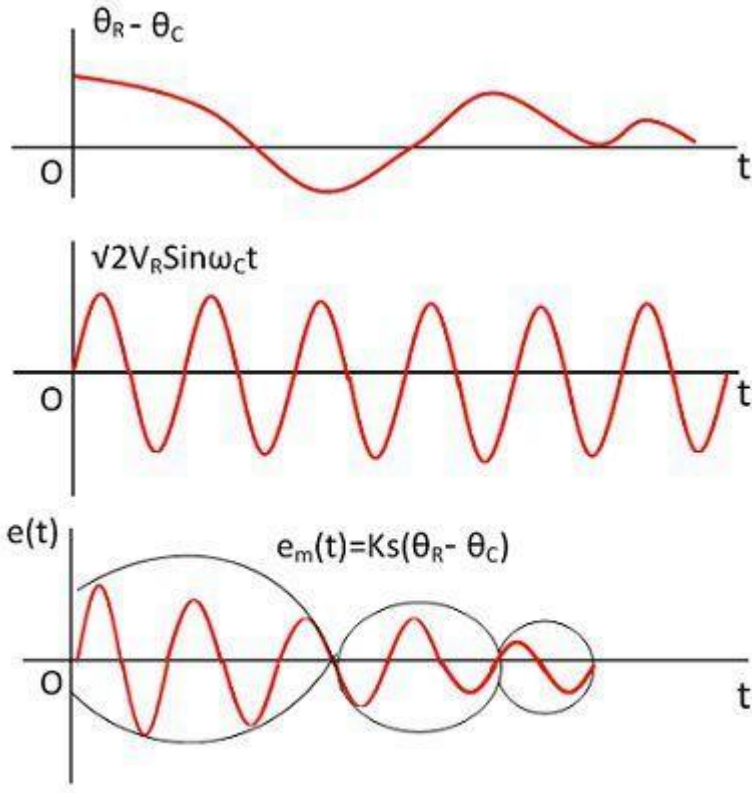

Waveform of Synchro Error Detector

Circuit Globe

The figure above shows the output of the synchro error detector which is a modulated signal. The modulating wave above shown the misalignment between the rotor position and the carrier wave.

$$e(t) = (\theta_R - \theta_C)$$

Where  $K_s$  is the error detector.

**SYNCHRO CONTROL TRANSFORMER**

Construction

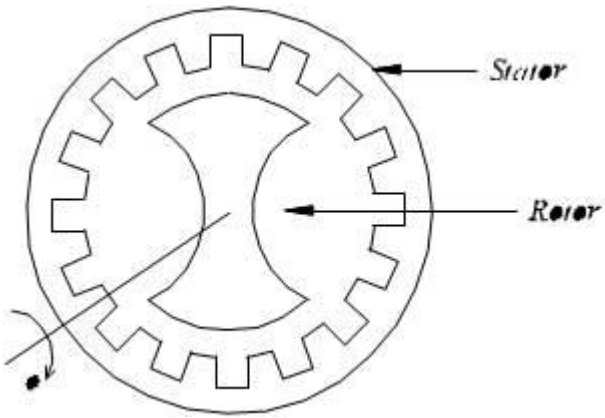

Figure – 4a Constructional Features

The constructional features of **synchro control transformer** are similar to that of **Synchro Transmitter**, except the shape of rotor. The rotor of the control transformer is made cylindrical so that the air gap is practically uniform. This feature of the control transformer minimizes the changes in the rotor impedance with the rotation of the shaft. The constructional features, electrical circuit and a schematic symbol of control transformer are shown in figure 4.

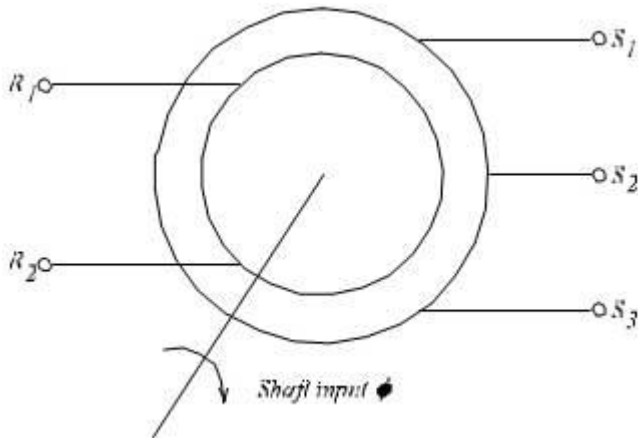

Figure – 4b Schematic Symbol of **synchro control**

**transformer**

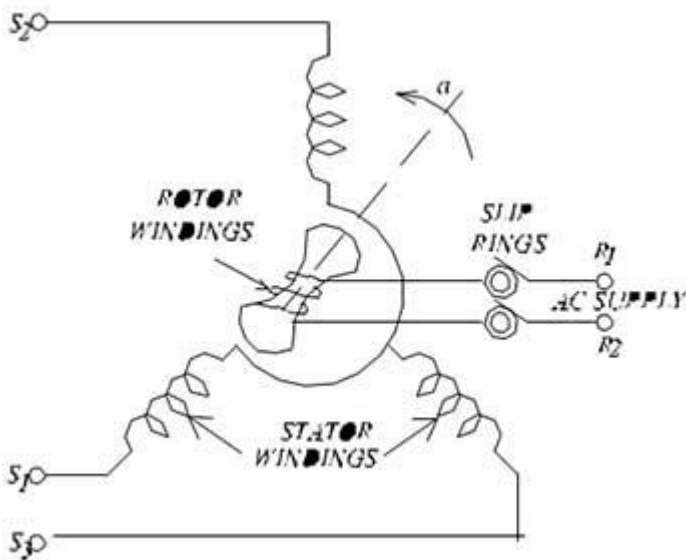

Figure – 4c Electrical Circuit of **synchro control**

**transformer**

Working

The generated emf of the **Synchro Transmitter** is applied as input to the stator coils of control transformer. The rotor shaft is connected to the load whose position has to be maintained at the desired value. Depending on the current position of the rotor and the applied emf on the stator, an emf is induced on the rotor winding. This emf can be measured and used to drive a motor so that the position of the load is corrected

### 3.3 Electrical Tachometer

**Definition:** The tachometer use for measuring the rotational speed or angular velocity of the machine which is coupled to it. It works on the principle of relative motion between the magnetic field and shaft of the coupled device. The relative motion induces the EMF in the coil which is placed between the constant magnetic field of the permanent magnet. The develops EMF is directly proportional to the speed of the shaft.

Mechanical and electrical are the two types of the tachometer. The mechanical tachometer measures the speed of shaft regarding revolution per minutes.

The electrical tachometer converts the angular velocity into an electrical voltage. The electrical tachometer has more advantages over the mechanical tachometer. Thus it is mostly used for measuring the rotational speed of the shaft. Depends on the natures of the induced voltage the electrical tachometer is categorized into two types.

- AC Tachometer Generator
- DC Tachometer Generator

#### **DC Tachometer Generator**

Permanent magnet, armature, commutator, brushes, variable resistor, and the moving coil voltmeter are the main parts of the DC tachometer generator. The machine whose speed is to be measured is coupled with the shaft of the DC tachometer generator.

The DC tachometer works on the principle that when the closed conductor moves in the magnetic field, EMF induces in the conductor. The magnitude of the induces emf depends on the flux link with the conductor and the speed of the shaft.

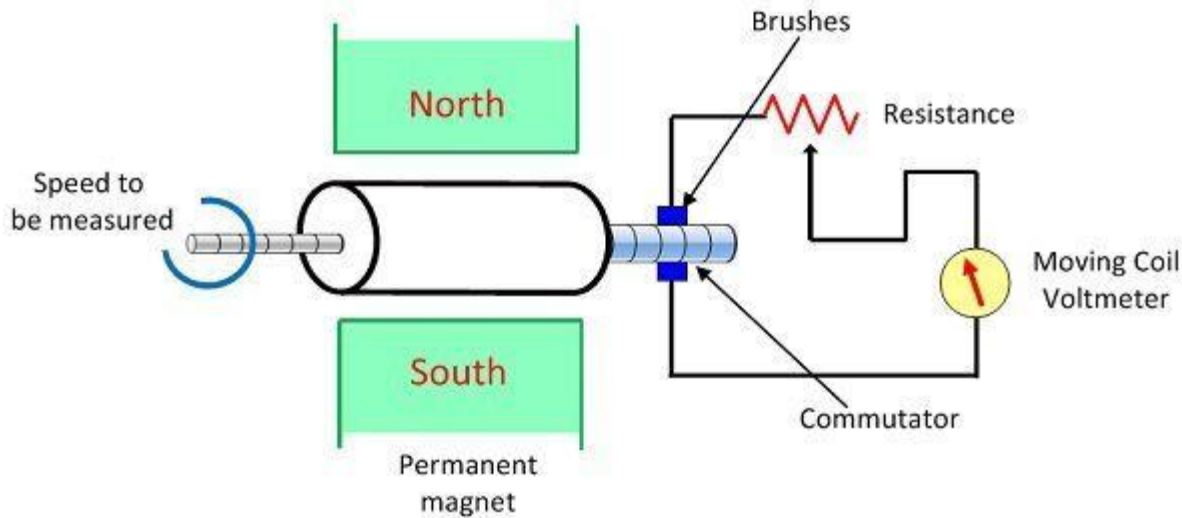

## DC Tachometer Generator

Circuit Globe

The

armature of the DC generator revolves between the constant field of the permanent magnet. The rotation induces the emf in the coil. The magnitude of the induced emf is proportional to the shaft speed.

The commutator converts the alternating current of the armature coil to the direct current with the help of the brushes. The moving coil voltmeter measures the induced emf. The polarity of the induced voltage determines the direction of motion of the shaft. The resistance is connected in series with the [voltmeter](#) for controlling the heavy current of the armature.

The emf induced in the dc tachometer generator is given as

$$E = \frac{\Phi P N}{60} \times \frac{z}{a}$$

Where, E – generated voltage

$\Phi$  – flux per poles in Weber

P- number of poles

N – speed in revolution per minutes

Z – the number of the conductor in armature windings.

a – number of the parallel path in the armature windings.

$$E \propto N$$

$$E = KN$$

$$K = \text{Constant} = \frac{\Phi P}{60} \times \frac{z}{a}$$

**Advantages of the DC Generator**

The following are the advantages of the DC Tachometer.

- The polarity of the induced voltages indicates the direction of rotation of the shaft.
- The conventional DC type voltmeter is used for measuring the induced voltage.

### Disadvantages of DC Generator

- The commutator and brushes require the periodic maintenance.
- The output resistance of the DC tachometer is kept high as compared to the input resistance. If the large current is induced in the armature conductor, the constant field of the permanent magnet will be distorted.

### AC Tachometer Generator

The DC tachometer generator uses the commutator and brushes which have many disadvantages. The AC tachometer generator designs for reducing the problems. The AC tachometer has stationary armature and rotating magnetic field. Thus, the commutator and brushes are absent in AC tachometer generator.

The rotating magnetic field induces the EMF in the stationary coil of the stator. The amplitude and frequency of the induced emf are equivalent to the speed of the shaft. Thus, either amplitude or frequency is used for measuring the angular velocity.

The below mention circuit is used for measuring the speed of the rotor by considering the amplitude of the induced voltage. The induced voltages are rectified and then passes to the capacitor filter for smoothing the ripples of rectified voltages.

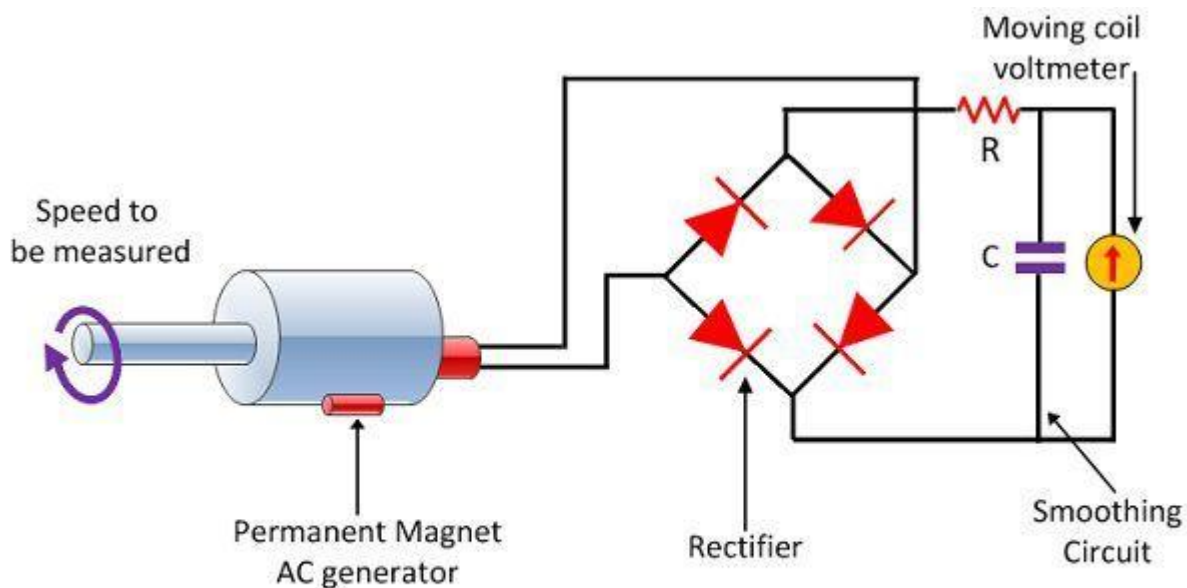

### A.C Tachometer Generator

Circuit Globe

Drag Cup

### Rotor AC Generator

The drag cup type A.C tachometer is shown in the figure below.

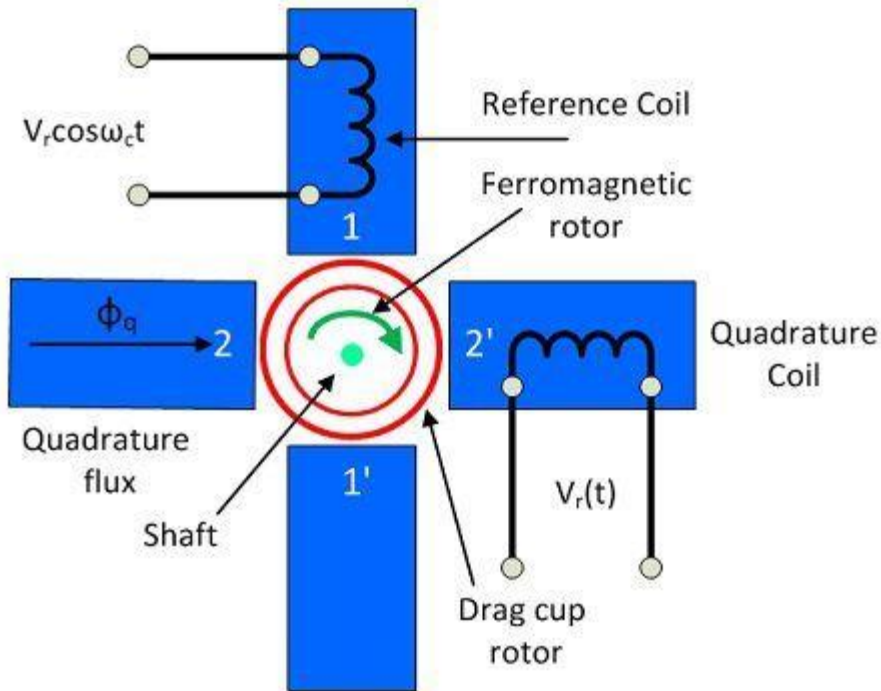

## A.C Tachometer Generator

Circuit Globe

The stator of the generator consists two windings, i.e., the reference and quadrature winding. Both the windings are mounted  $90^\circ$  apart from each other. The rotor of the tachometer is made with thin aluminium cup, and it is placed between the field structure.

The rotor is made of the highly inductive material which has low inertia. The input is provided to the reference winding, and the output is obtained from the quadrature winding. The rotation of rotor between the magnetic field induces the voltage in the sensing winding. The induced voltage is proportional to the speed of the rotation.

### Advantages

- The drag cup Tachogenerator generates the ripple free output voltage.
- The cost of the generator is also very less.

### Disadvantage

The nonlinear relationship obtains between the output voltage and input speed when the rotor rotates at high speed.

The following are the advantages of the DC Tachometer.

- The polarity of the induced voltages indicates the direction of rotation of the shaft.
- The conventional DC type voltmeter is used for measuring the induced voltage.

## Disadvantages of DC Generator

- The commutator and brushes require the periodic maintenance.
- The output resistance of the DC tachometer is kept high as compared to the input resistance. If the large current is induced in the armature conductor, the constant field of the permanent magnet will be distorted.

## Servo Motor

**Servo Motor** are also called Control motors. They are used in feedback control systems as output actuators and does not use for continuous energy conversion. The principle of the Servomotor is similar to that of the other electromagnetic motor, but the construction and the operation are different. Their power rating varies from a fraction of a watt to a few hundred watts.

The rotor inertia of the motors is low and have a high speed of response. The rotor of the Motor has the long length and smaller diameter. They operate at very low speed and sometimes even at the zero speed. The servo motor is widely used in radar and computers, robot, machine tool, tracking and guidance systems, processing controlling, etc.

## Applications of the Servo Motor

The power rating of the servo motor may vary from the fraction of watts to few hundreds of watts. The rotor of servo motor have low inertia strength, and therefore they have a high speed of inertia. The Applications of the Servomotor are as follows:-

- They are used in Radar system and process controller.
- Servomotors are used in computers and robotics.
- They are also used in machine tools.
- Tracking and guidance systems.

## Classification of Servo Motor

They are classified as AC and DC Servo Motor. The AC servomotor is further divided into two types.

- [Two Phase AC Servo Motor](#)
- Three Phase AC Servo Motor

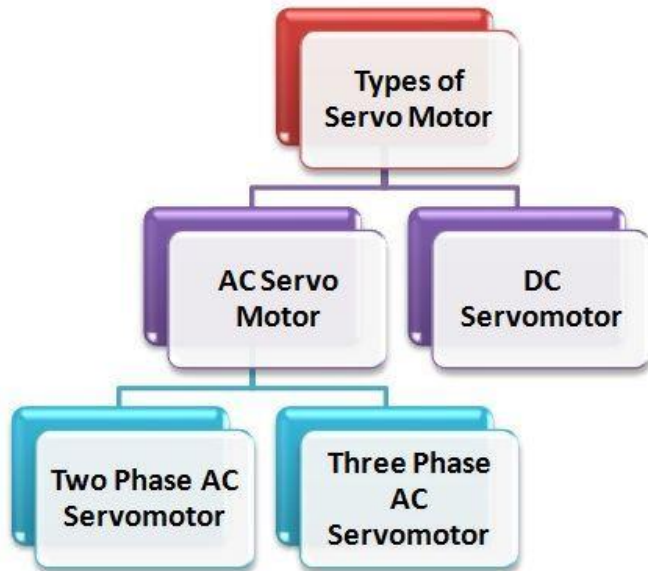

### 3.3 DC servomotor

DC Servo Motors are separately excited DC motor or permanent magnet DC motors. The figure (a) shows the connection of Separately Excited DC Servo motor and the figure (b) shows the armature MMF and the excitation field MMF in quadrature in a DC machine.

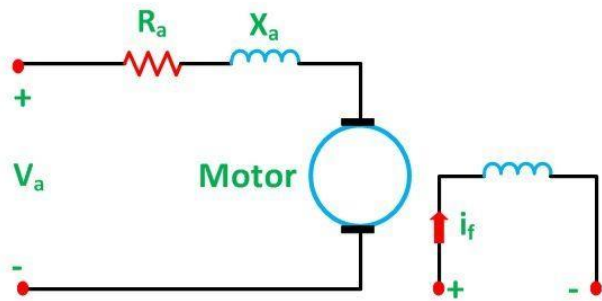

Figure a

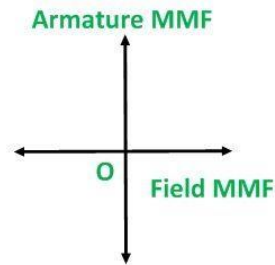
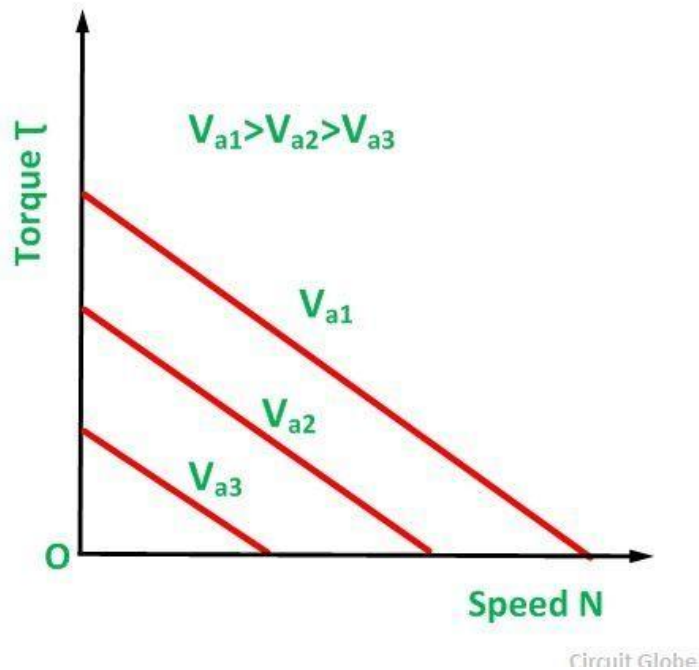

Figure b

Circuit Globe

This provides a fast torque response because torque and flux are decoupled. Therefore, a small change in the armature voltage or current brings a significant shift in the position or speed of the rotor. Most of the high power servo motors are mainly DC.

The Torque-Speed Characteristics of the Motor is shown below.



As from the above characteristics, it is seen that the slope is negative. Thus, a negative slope provides viscous damping for the servo drive system.

### 3.4 AC Servo Motor

#### *AC Servo Motors*

AC servo motors are basically two-phase squirrel cage induction motors and are used for low power applications. Nowadays, three phase squirrel cage induction motors have been modified such that they can be used in high power servo systems.

The main difference between a standard split-phase induction motor and AC motor is that the squirrel cage rotor of a servo motor has made with thinner conducting bars, so that the motor resistance is higher.

## AC Servo Motor

Based on the construction there are two distinct types of AC servo motors, they are synchronous type AC servo motor and induction type AC servo motor.

**Synchronous-type AC servo motor** consist of stator and rotor. The stator consists of a cylindrical frame and stator core. The armature coil wound around the stator core and the coil end is connected to with a lead wire through which current is provided to the motor.

The rotor consists of a permanent magnet and hence they do not rely on AC induction type rotor that has current induced into it. And hence these are also called as brushless servo motors because of structural characteristics.

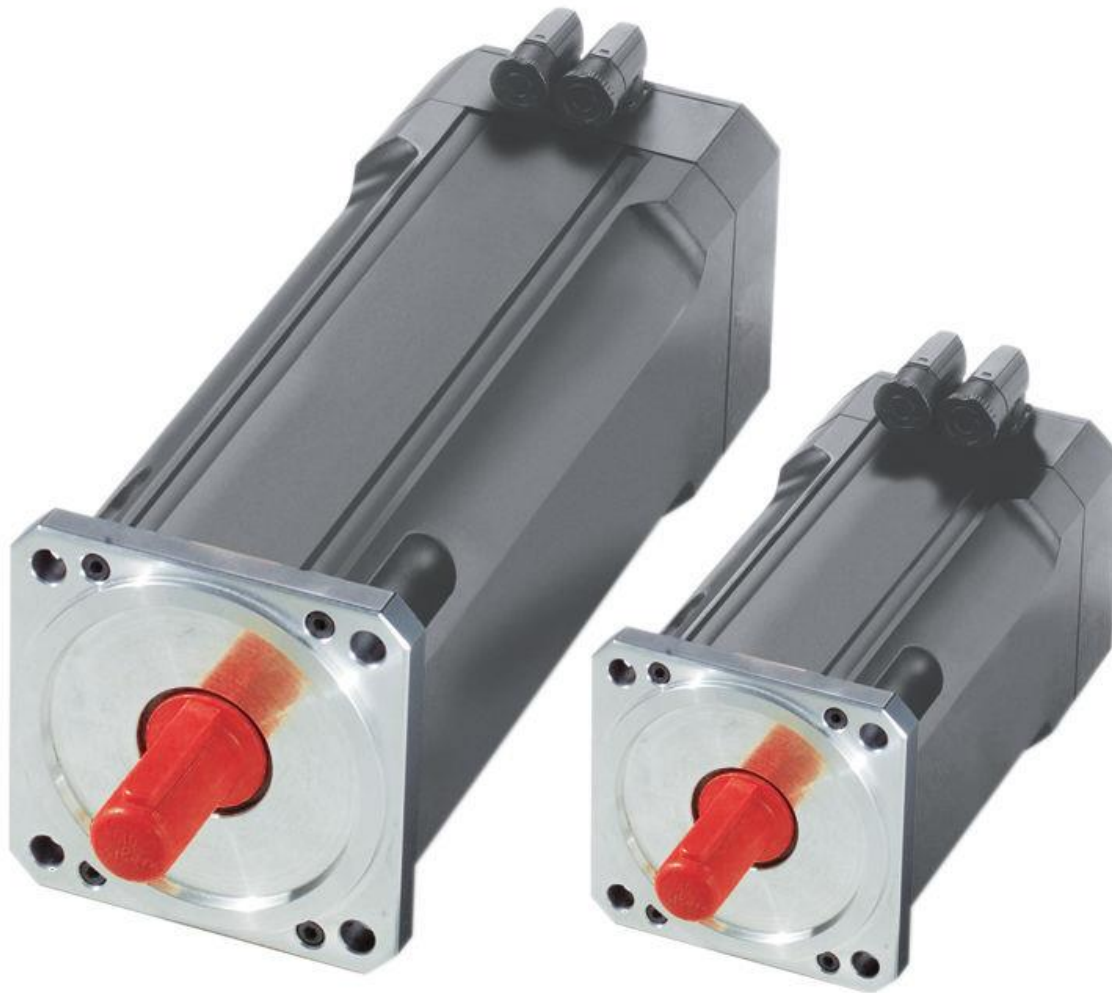

### Synchronous-type AC servo motor

When the stator field is excited, the rotor follows the rotating magnetic field of the stator at the synchronous speed. If the stator field stops, the rotor also stops. With this permanent magnet rotor, no rotor current is needed and hence less heat is produced.

Also, these motors have high efficiency due to the absence of rotor current. In order to know the position of rotor with respect to stator, an encoder is placed on the rotor and it acts as a feedback to the motor controller.

The **induction-type AC servo motor** structure is identical with that of general motor. In this motor, stator consists of stator core, armature winding and lead wire, while rotor consists of shaft and the rotor core that built with a conductor as similar to squirrel cage rotor.



### induction-type AC servo motor

The working principle of this servo motor is similar to the normal induction motor. Again the controller must know the exact position of the rotor using encoder for precise speed and position control.

#### *Working Principle of AC Servo Motor*

The schematic diagram of servo system for AC two-phase induction motor is shown in the figure below. In this, the reference input at which the motor shaft has to maintain at a certain position is given to the rotor of synchro generator as mechanical input  $\theta$ . This rotor is connected to the electrical input at rated voltage at a fixed frequency.

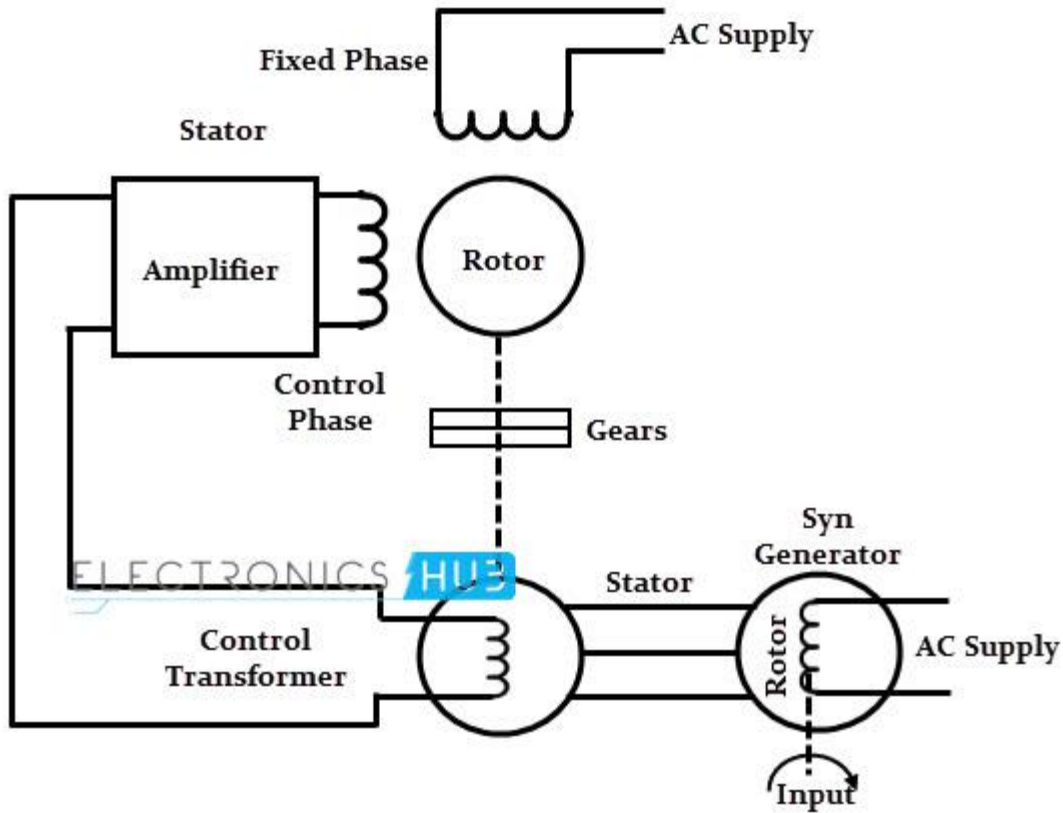

The three stator terminals of a synchro generator are connected correspondingly to the terminals of control transformer. The angular position of the two-phase motor is transmitted to the rotor of control transformer through gear train arrangement and it represents the control condition alpha.

Initially, there exist a difference between the synchro generator shaft position and control transformer shaft position. This error is reflected as the voltage across the control transformer. This error voltage is applied to the servo amplifier and then to the control phase of the motor.

With the control voltage, the rotor of the motor rotates in required direction till the error becomes zero. This is how the desired shaft position is ensured in AC servo motors.

Alternatively, modern AC servo drives are embedded controllers like PLCs, microprocessors and microcontrollers to achieve variable frequency and variable voltage in order to drive the motor.

Mostly, pulse width modulation and Proportional-Integral-Derivative (PID) techniques are used to control the desired frequency and voltage. The block diagram of AC servo motor system using programmable logic controllers, position and servo controllers is given below.

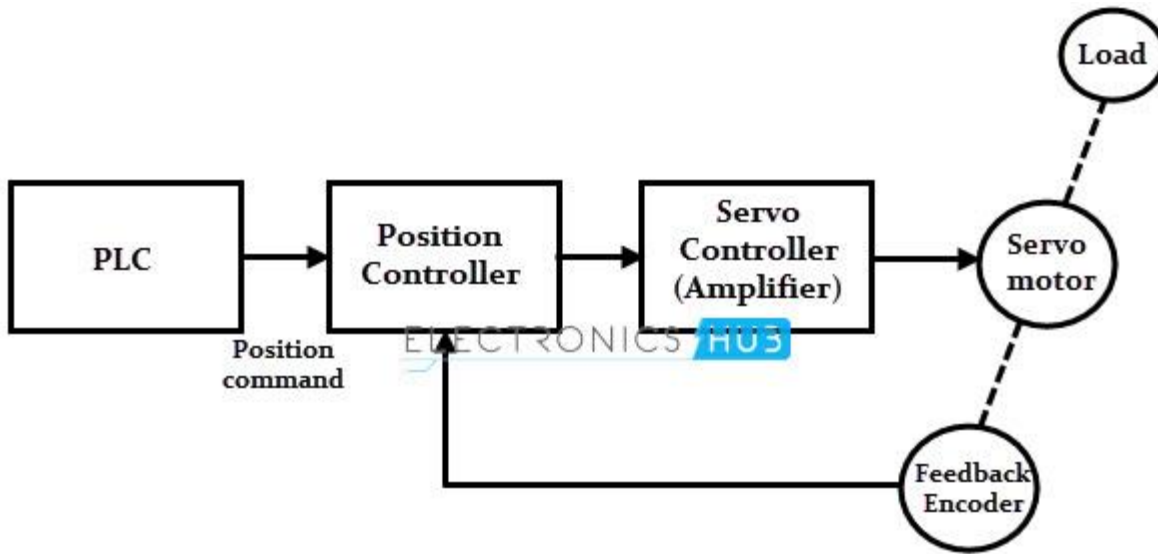

#### Difference between the DC and AC Servo Motors

DC SERVO MOTOR	AC SERVO MOTOR
It delivers high power output	Delivers low output of about 0.5 W to 100 W
It has more stability problems	It has less stable problems
It requires frequent maintenance due to the presence of commutator	It requires less maintenance due to the absence of commutator
It provides high efficiency	The efficiency of AC servo motor is less and is about 5 to 20%
The life of DC servo motor depends on the life on brush life	The life of AC servo motor depends on bearing life
It includes permanent magnet in its construction	The synchronous type AC servo motor uses permanent magnet while the asynchronous type uses induction motor
These motors are used for high power applications	These motors are used for low power applications

## Short questions

1. Define Gyroscope

Ans-it is an instrument used in spaceship and aircrafts. The input is the angular velocity and the output is the angular displacement

2. Define tachometer?

Ans-it is a miniature low voltage generator where the output voltage of generator is given by  $E_f = k\omega$

3. Define synchro?

Ans-it is an electromechanical device that produces an output voltage depending on the angular position of rotor and not on rotor speed

## Long questions

1. Explain synchro transmitter?

2. Explain synchro receiver?

Explain with diagram dc and ac servo motor?

## Ch-4

### Block diagram algebra and signal flow graph

Block diagrams consist of a single block or a combination of blocks. These are used to represent the control systems in pictorial form.

#### Basic Elements of Block Diagram

The basic elements of a block diagram are a block, the summing point and the take-off point. Let us consider the block diagram of a closed loop control system as shown in the following figure to identify these elements.

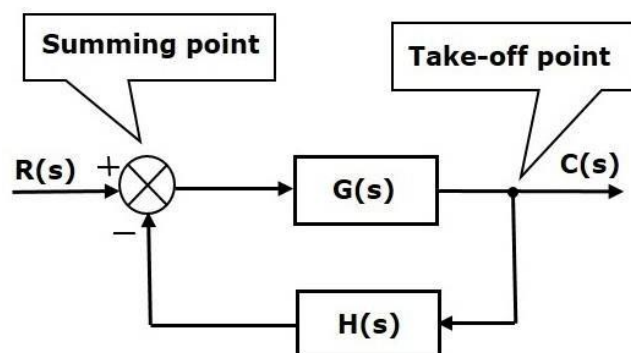

The above block diagram consists of two blocks having transfer functions  $G(s)$  and  $H(s)$ . It is also having one summing point and one take-off point. Arrows indicate the direction of the flow of signals. Let us now discuss these elements one by one.

### Block

The transfer function of a component is represented by a block. Block has single input and single output.

The following figure shows a block having input  $X(s)$ , output  $Y(s)$  and the transfer function  $G(s)$ .

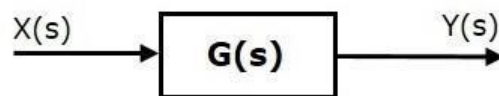

Transfer Function,  $G(s) = \frac{Y(s)}{X(s)}$

$$\Rightarrow Y(s) = G(s)X(s)$$

Output of the block is obtained by multiplying transfer function of the block with input.

### Summing Point

The summing point is represented with a circle having cross (X) inside it. It has two or more inputs and single output. It produces the algebraic sum of the inputs. It also performs the summation or subtraction or combination of summation and subtraction of the inputs based on the polarity of the inputs. Let us see these three operations one by one.

The following figure shows the summing point with two inputs (A, B) and one output (Y). Here, the inputs A and B have a positive sign. So, the summing point produces the output, Y as **sum of A and B**.

i.e.,  $Y = A + B$ .

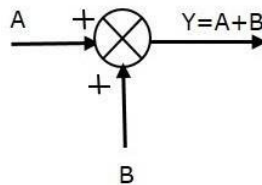

The following figure shows the summing point with two inputs (A, B) and one output (Y). Here, the inputs A and B are having opposite signs, i.e., A is having positive sign and B is having negative sign. So, the summing point produces the output Y as the **difference of A and B**.

$$Y = A + (-B) = A - B.$$

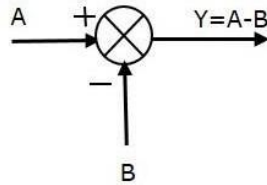

The following figure shows the summing point with three inputs (A, B, C) and one output (Y). Here, the inputs A and B are having positive signs and C is having a negative sign. So, the summing point produces the output **Y** as

$$Y = A + B + (-C) = A + B - C.$$

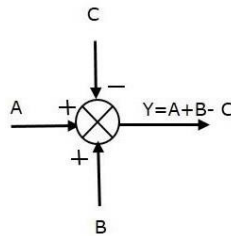

### Take-off Point

The take-off point is a point from which the same input signal can be passed through more than one branch. That means with the help of take-off point, we can apply the same input to one or more blocks, summing points.

In the following figure, the take-off point is used to connect the same input,  $R(s)$  to two more blocks.

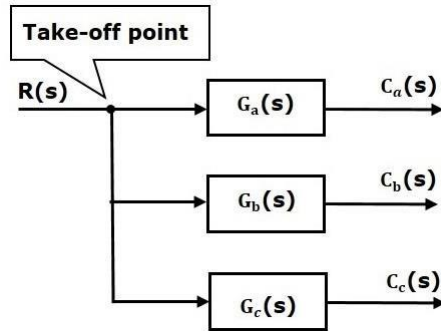

In the following figure, the take-off point is used to connect the output  $C(s)$ , as one of the inputs to the summing point.

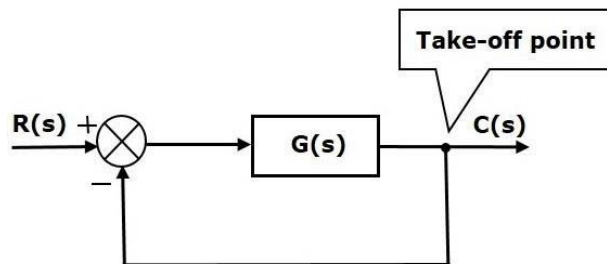

### Control Systems - Block Diagram Algebra

Block diagram algebra is nothing but the algebra involved with the basic elements of the block diagram. This algebra deals with the pictorial representation of algebraic equations.

Block diagram of a closed loop system.

Fig2.3 shows an example of a block diagram of a closed system

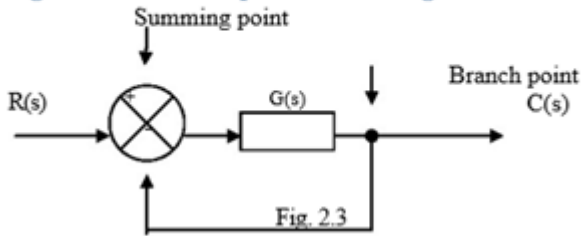

The output  $C(s)$  is fed back to the summing point, where it is compared with reference input  $R(s)$ . The closed loop nature is indicated in fig1.3. Any linear system may be represented by a block diagram consisting of blocks, summing points and branch points. A branch is the point from which the output signal from a block diagram goes concurrently to other blocks or summing points.

When the output is fed back to the summing point for comparison with the input, it is necessary to convert the form of output signal to that of the input signal. This conversion is followed by the feed back element whose transfer function is  $H(s)$  as shown in fig 1.4. Another important role of the feed back element is to modify the output before it is compared with the input.

input.

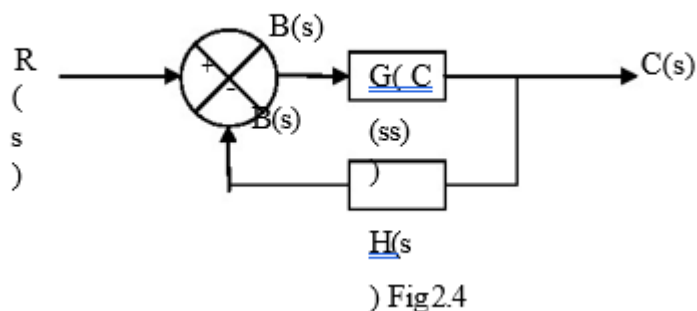

Fig2.4

The ratio of the feed back signal  $B(s)$  to the actuating error signal  $E(s)$  is called the open loop transfer function.

$$\text{open loop transfer function} = B(s)/E(s) = G(s)H(s)$$

The ratio of the output  $C(s)$  to the actuating error signal  $E(s)$  is called the feed forward transfer function .

$$\text{Feed forward transfer function} = C(s)/E(s) = G(s)$$

If the feed back transfer function is unity, then the open loop and feed forward transfer function are the same. For the system shown in Fig1.4, the output  $C(s)$  and input  $R(s)$  are related as follows.

$$C(s) = G(s) E(s)$$

$$E(s) = R(s) - B(s)$$

$$= R(s) - H(s) C(s) \quad \text{but}$$

$$B(s) = H(s)C(s) \text{ Eliminating } E(s) \text{ from these equations}$$

$$C(s) = G(s) [R(s) - H(s) C(s)]$$

$$C(s) + G(s) [H(s) C(s)] = G(s) R(s)$$

$$C(s)[1 + G(s)H(s)] = G(s)R(s)$$

$$C(s)/R(s) = \frac{G(s)}{1+G(s)H(s)}$$

$C(s)/R(s)$  is called the closed loop transfer function.

The output of the closed loop system clearly depends on both the closed loop transfer function and the nature of the input. If the feed back signal is positive, then

$$C(s)/r(s) = \frac{G(s)}{1+G(s)H(s)}$$

### canonical form of closed loop block diagram

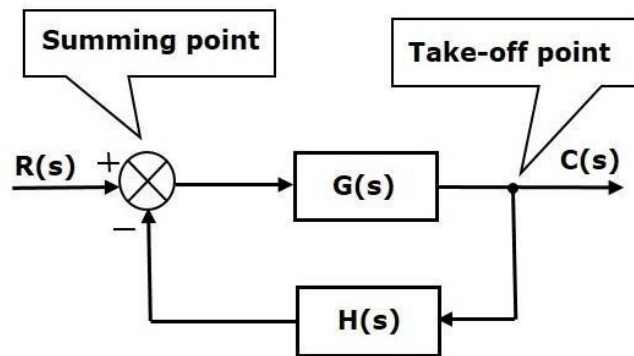

This figure shows a block diagram which consists of a forward path having one block, a feedback path having one block, a take-off point, and a summing point. It represents a canonical form of a closed-loop system.  $R(s)$  is the Laplace transform of the reference input,  $C(s)$  is the Laplace transform of the controlled output  $c(t)$ ,  $E(s)$  is the Laplace transform of the error signal  $e(t)$ ,  $B(s)$  is the Laplace transform of the feedback signal  $b(t)$ .  $C(s)$  is the equivalent forward path transfer function,  $H(s)$  is the equivalent feedback path transfer function.

#### 4.4: Procedure for reduction of block diagram

##### Rule 1: Associative law

In the below figure two summing points have been taken into account. In the 1<sup>st</sup> case the output is  $R_1(s) - R_2(s) + R_3(s)$ . In figure b the positions of the summing points are interchanged. The output is  $R_1(s) + R_2(s) - R_3(s)$ .

From figure a and b

$$R_1(s) + R_3(s) - R_2(s)$$

### 6.3 RULES FOR BLOCK DIAGRAM REDUCTION

Any complicated system can be brought into simple form by reduction of block diagram. The following are used in block diagram reduction.

#### Rule 1: Associative law

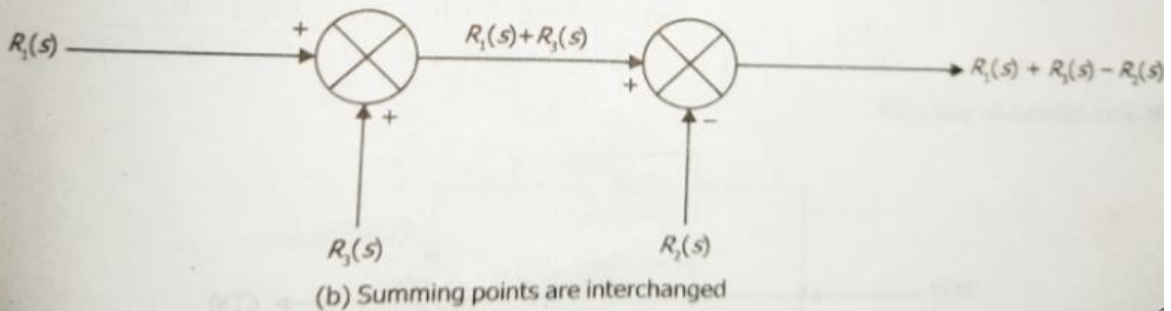
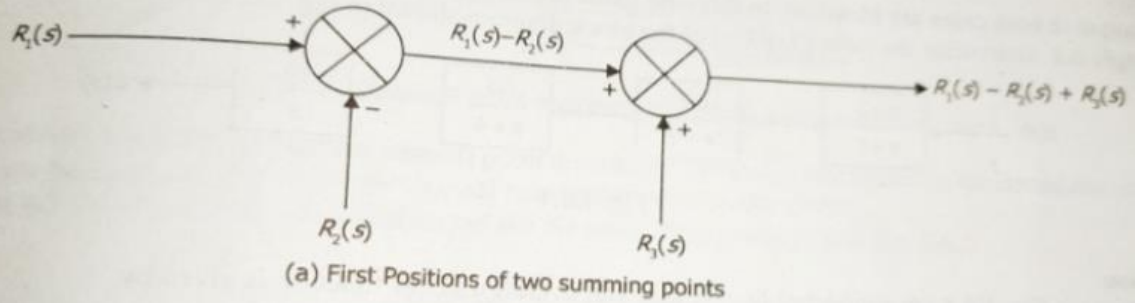

#### Rule 2: Blocks In Series/cascade

Any finite specific number of blocks arranged in series can be combined together by multiplication as shown below:

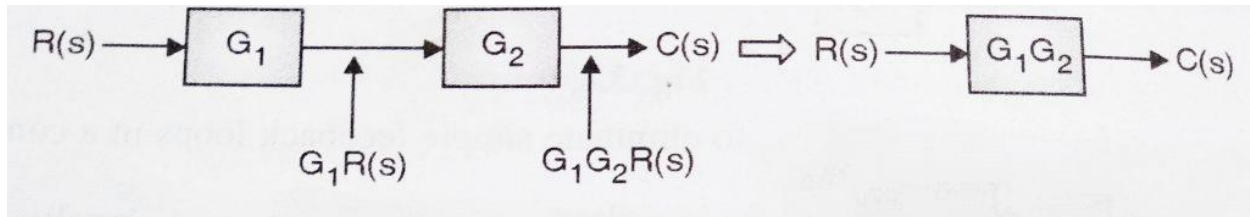

The above blocks shown can be combined together and replaced with single block as

**Output  $C(s) = G_1 \times G_2 \times R(s)$**

If there is a take-off point or summing point between the blocks, the blocks cannot be said to be in cascade/series. (the take-off/summing point has to be shifted before or after the block using another rule)

#### Rule 3: Blocks In Parallel

When the blocks are connected in parallel combination, they get added algebraically (considering the sign of the signal)

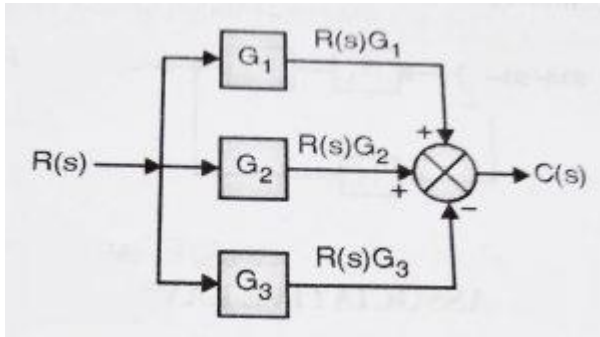

this can be combined as(refer both the diagrams)

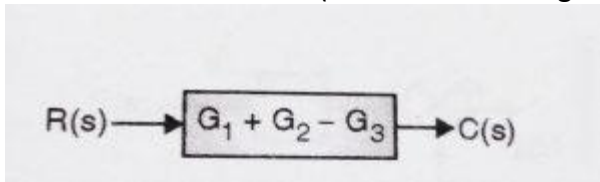

The above blocks can be replaced with a single block as

$$C(s) = R(s)G_1 + R(s)G_2 - R(s)G_3$$

$$C(s) = R(s) (G_1 + G_2 - G_3)$$

If any summing point/take-off point is present in between the blocks, then that has to be shifted first.(in a parallel arrangement, the direction of signal flow must be in the same direction through all the blocks)

#### Rule 4: Elimination of feedback Loop

We can use [Closed loop transfer function](#) to eliminate the feedback loop present.(Always remember for applying this method the direction of flow of signals should be in opposite direction, otherwise, if they are in the same direction, then we need to apply parallel reduction technique discussed above)

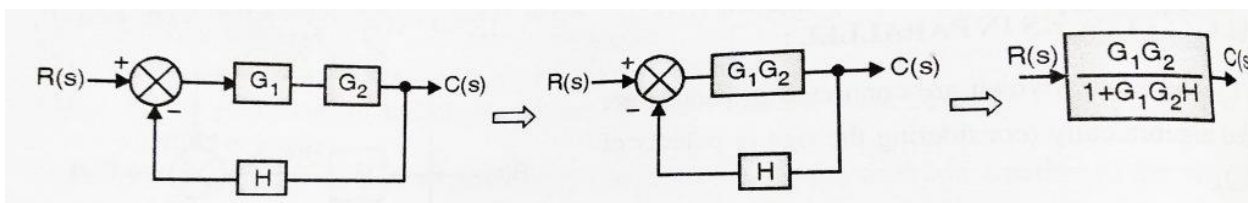

Now consider the application of the above three rules together and refer to the block diagram above.

#### Rule 5: Shifting of a Summing Point before a block

When we shift the summing point before a block, we need to do the transformation in order to achieve the same result. Please refer to the diagram below :

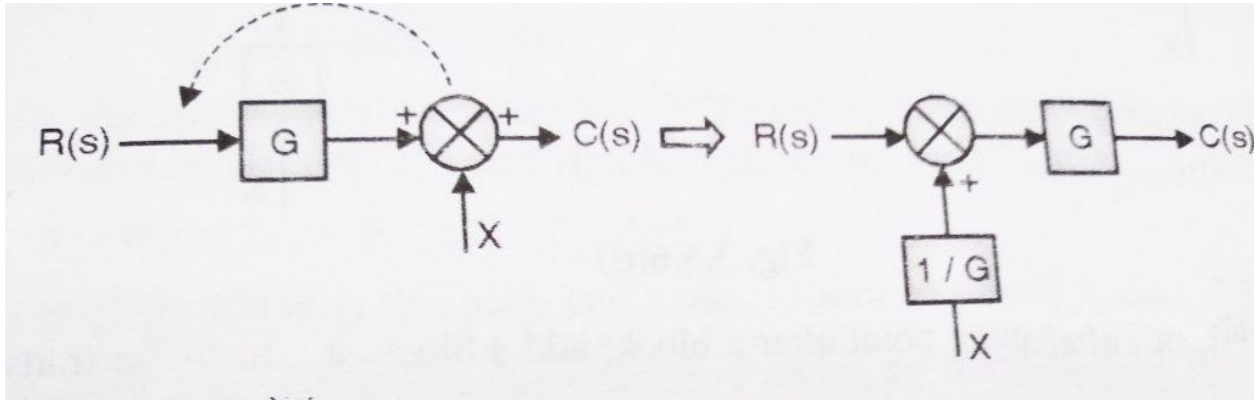

$$C(s) = GR(s) + X$$

After shifting the summing point, we will get

$$C(s) = [R + (X/G)] G = GR + X$$

which is same as output in the first case.

Hence to shift a summing point before a block, we need to add another block of transfer function '1/G' before the summing point as shown in figure

**Rule 6: Shifting of the Summing Point after a block**

When we generally shift the summing point after any block, we required to do the transformation to attain the same (required) result. Please refer the below diagram .

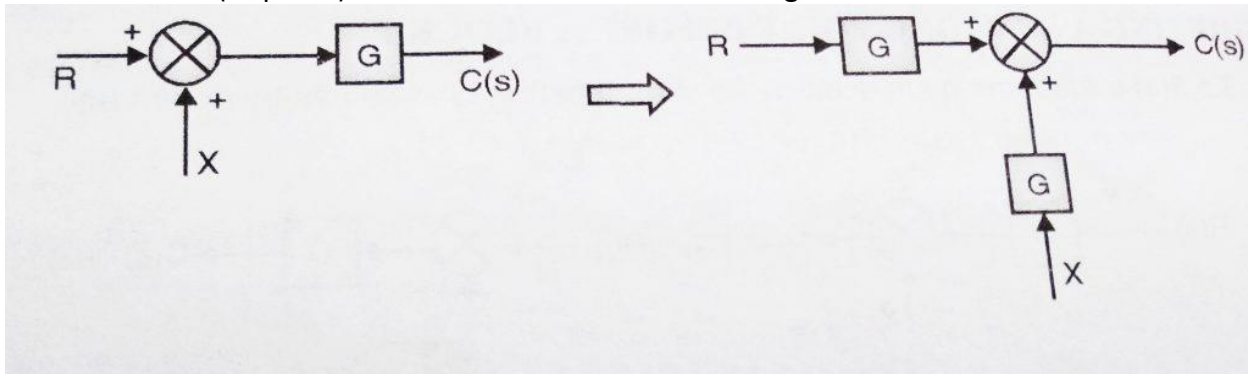

$$C(s) = (R + X)G$$

After shifting the summing point, we will get

$$C(s) = (R + X) G = GR + XG$$

which is same as output in the first case.

Hence to shift a summing point after a block, we need to add another block having the same transfer function at the summing point as shown in fig

**Rule 6: Shifting of Take-off point after a block**

Here we want to shift the take – off point after a block, as shown in the diagram

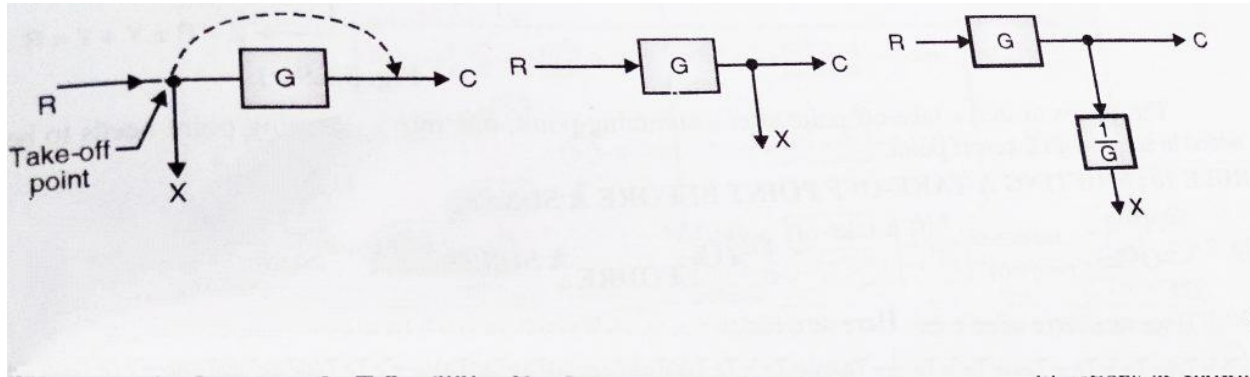

Here we have  $X = R$  and  $C = RG$  (initially)

In order to achieve this, we need to add a block of transfer function '1/G' in series with signal taking off from that point.

**Rule 8 : Shifting of Take-off point before a block**

Here we want to shift the take – off point before a block, as shown in the diagram

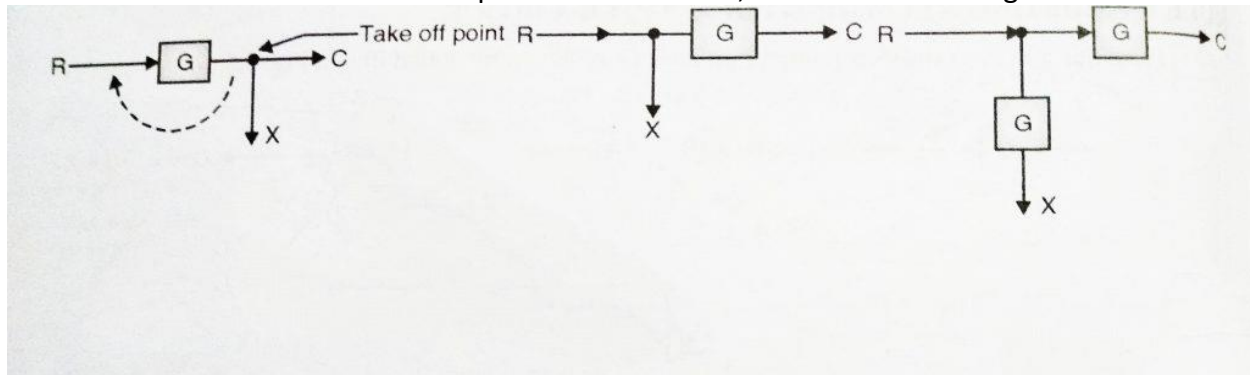

Here we have  $X = R$  and  $C = RG$  (initially)

In order to achieve this, we need to add a block of transfer function 'G' in series with X signal taking off from that point.

**Rule 9: Shifting a Take-off point after a Summing Point**

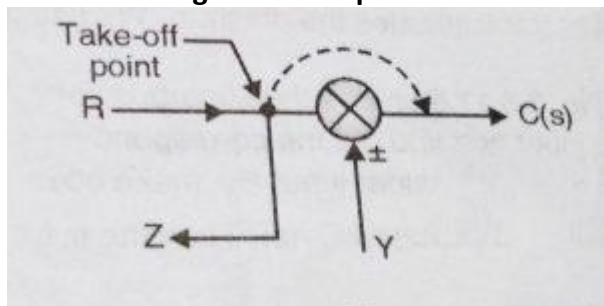

can be transformed to (refer both the diagrams)

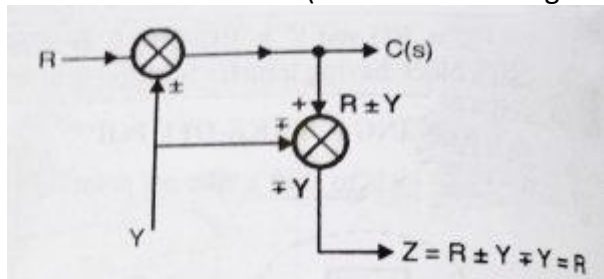

Before shifting take-off point, initially, we have:

$$C(s) = R \pm Y$$

and  $Z = R \pm Y$  (initially)

Hence if we want to shift a take-off point after a summing point, one more summing point needs to be added in series with take-off point.

**Rule 10: Shifting a take-off point before a summing point**

Suppose if we want to shift take-off point before a summing point, then initially we have

$$C(s) = R \pm Y$$

and  $Z = R \pm Y$  (initially)

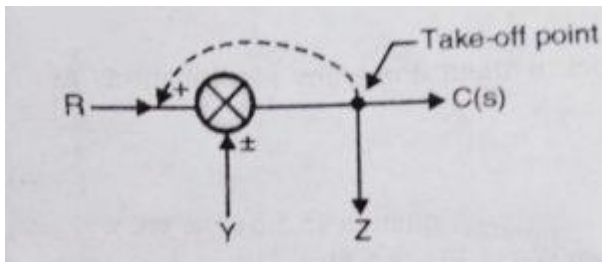

this can be transformed to (refer both the diagrams)

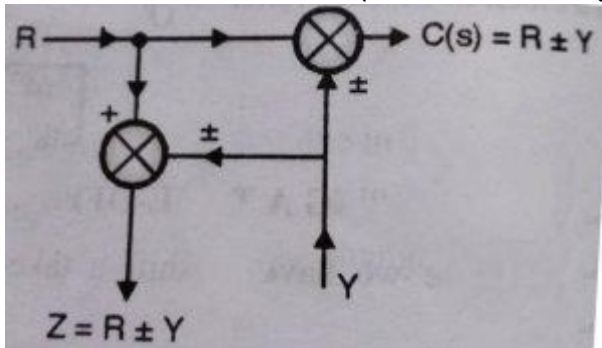

In order to satisfy this condition, we need to add a summing point in series with the take-off point.

**4.4: Procedure for reduction of block diagram**

Step-1-reduce the cascade blocks

Step-2-reduce the parallel blocks

Step-3-Reduce the internal feedback loop

Step-4-shift take offpoint towards right and summing point towards left

Step-5-repeat step 1 and step 4 untill the simple form is obtained

Step-6-find transfer function of the over all system using the formula  $c(s)/r(s)$

**Procedure for multiple input**

Step-1-Here reduce all but one input is zero .Find resultant output

Step-2- Reduce step 1 untill all input is covered

Step-3-Find the resultant output by superposition

**Simple Problem for equivalent transfer function**

Procedure for multiple inputs:  
**Step 1:** Here reduce all but one inputs are covered.  
**Step 2:** Repeat step 1 until all inputs are covered.  
**Step 3:** Find the resultant output by superposition.  
**Example 6.4** Determine the ratio  $C(s)/R(s)$  of the block diagram shown in Fig. E6.4.

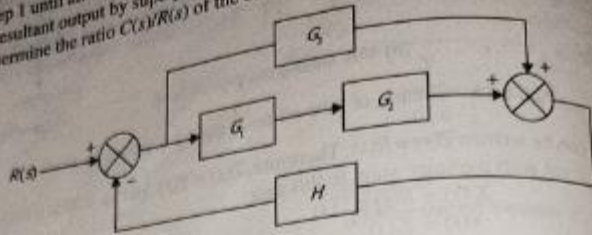

Fig. E6.4

**Solution**

$G_1$  and  $G_2$  are connected in cascade and their equivalent is connected in parallel with  $G_3$ .

$$G = G_1 G_2 + G_3$$

$$\frac{C(s)}{R(s)} = \frac{G(s)}{1 - G(s)H(s)} = \frac{G_1 G_2 + G_3}{1 - (G_1 G_2 + G_3)H}$$

**Example 6.5** Find  $C(s)/R(s)$  of the block diagram shown in Fig. E6.5.

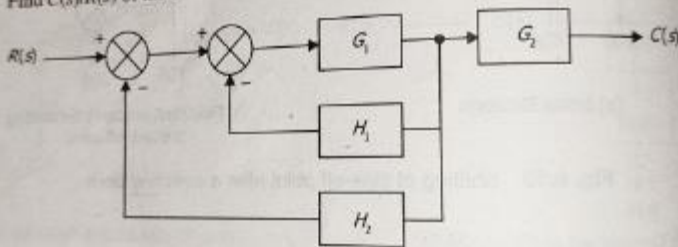

Fig. E6.5

**Solution**

Figure E6.5 is redrawn and shown in Fig. E6.5(a).

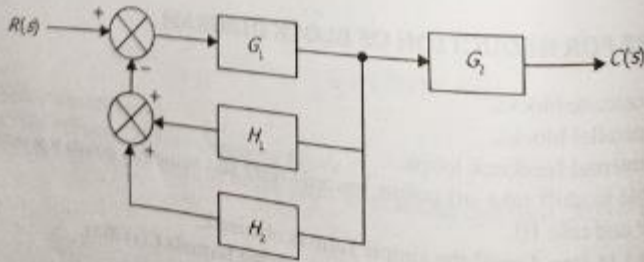

Fig. E6.5(a)

Since the two feedback loops are parallel, Fig. E6.5(a) becomes

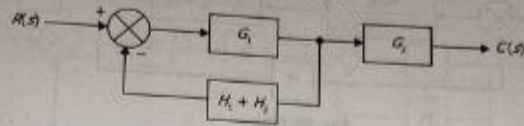

Fig. E6.5(b)

Replacing the feedback loop of Fig. E6.5(b) by its equivalent block, Fig. E6.5(b) becomes

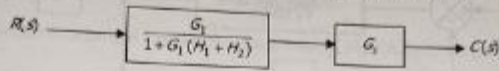

Fig. E6.5(c)

$$\frac{C(s)}{R(s)} = \frac{G_1 G_2}{1 + G_1(H_1 + H_2)}$$

**Example 6.6** Find the single block equivalent of Figure E6.6.

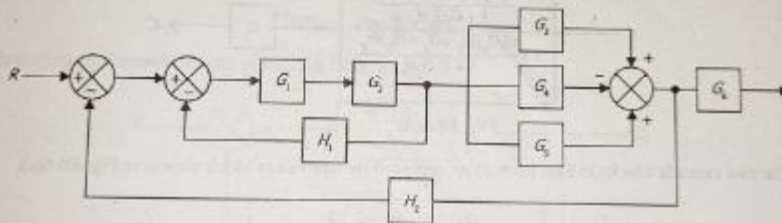

Fig. E6.6

**Solution**

At first the cascade and parallel blocks of Fig. E6.6 are reduced as shown in Fig. E6.6(a).

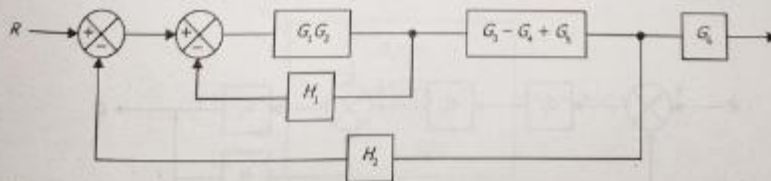

Fig. E6.6(a)

The first internal feedback loop of Fig. E6.6(a) is reduced by its equivalent block shown in Fig. E6.6(b).

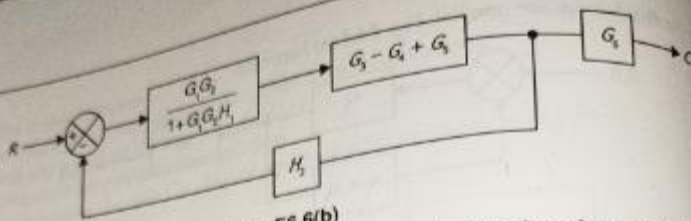

Fig. E6.6(b)

The cascade blocks of Fig. E6.6(b) are replaced by its equivalent block as shown in Fig. E6.6(c).

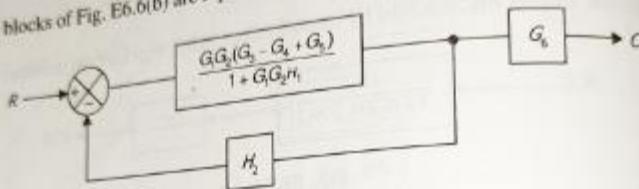

Fig. E6.6(c)

The feedback loop of Fig. E6.6(c) is replaced by its equivalent block shown in Fig. E6.6(d).

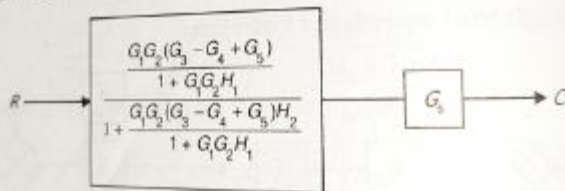

Fig. E6.6(d)

The two cascade blocks in Fig. E6.6(d) are replaced by equivalent block shown in Fig. E6.6(e).

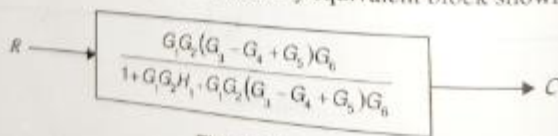
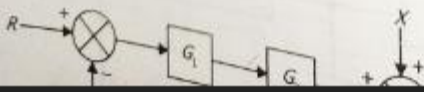

Fig. E6.6(e)

**Example 6.7** Find the output of the system shown in Fig. E6.7.



## Control Systems - Signal Flow Graphs

Signal flow graph is a graphical representation of algebraic equations. In this chapter, let us discuss the basic concepts related signal flow graph and also learn how to draw signal flow graphs.

### Basic Elements of Signal Flow Graph

Nodes and branches are the basic elements of signal flow graph.

Node

**Node** is a point which represents either a variable or a signal. There are three types of nodes — input node, output node and mixed node.

- **Input Node** – It is a node, which has only outgoing branches.
- **Output Node** – It is a node, which has only incoming branches.
- **Mixed Node** – It is a node, which has both incoming and outgoing branches.

### Example

Let us consider the following signal flow graph to identify these nodes.

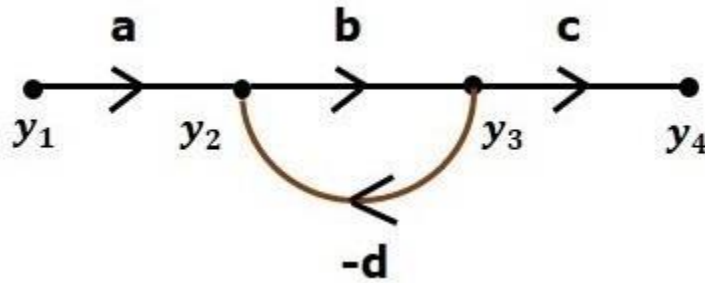

- The **nodes** present in this signal flow graph are **y1, y2, y3** and **y4**.
- **y1** and **y4** are the **input node** and **output node** respectively.
- **y2** and **y3** are **mixed nodes**.

### Branch

**Branch** is a line segment which joins two nodes. It has both **gain** and **direction**. For example, there are four branches in the above signal flow graph. These branches have **gains** of **a, b, c** and **-d**.

### Construction of Signal Flow Graph

Let us construct a signal flow graph by considering the following algebraic equations –

$$y_2 = a_{12}y_1 + a_{42}$$

$$y_4$$

$$y_3 = a_{23}y_2 + a_{53}$$

$$y_5 = a_{34}y_3$$

$$y_6 = a_{45}y_4 + a_{35}$$

$$y_3 = a_{56}y_5$$

There will be six **nodes** ( $y_1, y_2, y_3, y_4, y_5$  and  $y_6$ ) and eight **branches** in this signal flow graph.

The gains of the branches are  $a_{12}, a_{23}, a_{34}, a_{45}, a_{56}, a_{42}, a_{53}$  and  $a_{35}$ .

To get the overall signal flow graph, draw the signal flow graph for each equation, then combine all these signal flow graphs and then follow the steps given below –

**Step 1** – Signal flow graph for  $y_2 = a_{12}y_1 + a_{42}y_4$  is shown in the following figure.

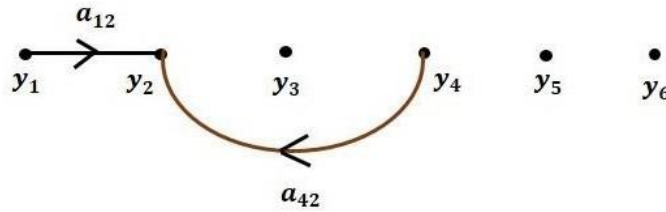

**Step 2** – Signal flow graph for  $y_3 = a_{23}y_2 + a_{53}y_5$  is shown in the following figure.

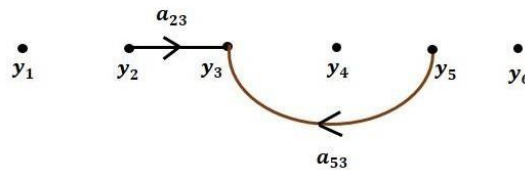

**Step 3** – Signal flow graph for  $y_4 = a_{34}y_3$  is shown in the following figure.

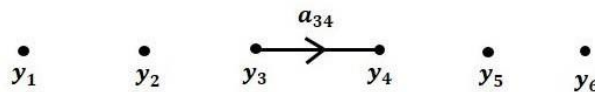

**Step 4** – Signal flow graph for  $y_5 = a_{45}y_4 + a_{35}y_3$  is shown in the following figure.

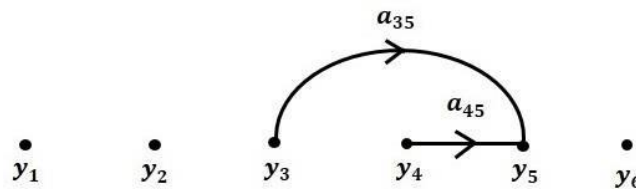

**Step 5** – Signal flow graph for  $y_6 = a_{56}y_5$  is shown in the following figure.



**Step 6** – Signal flow graph of overall system is shown in the following figure.

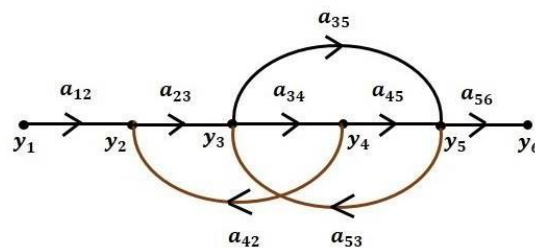

## Construction of Signal flow graph from Block Diagram

Follow these steps for converting a block diagram into its equivalent signal flow graph.

- Represent all the signals, variables, summing points and take-off points of block diagram as **nodes** in signal flow graph.
- Represent the blocks of block diagram as **branches** in signal flow graph.
- 
- Represent the transfer functions inside the blocks of block diagram as **gains** of the branches in signal flow graph.

- Connect the
- 
- nodes as per the block diagram. If there is connection between two nodes (but there is no block in between), then represent the gain of the branch as one. **For example**, between summing points, between summing point and takeoff point, between input and summing point, between take-off point and output.

### Example

Let us convert the following block diagram into its equivalent signal flow graph.

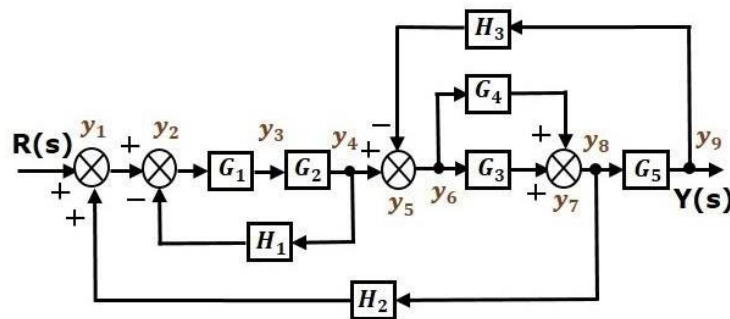

Represent the input signal  $R(s)$  and output signal  $C(s)$  of block diagram as input node  $R(s)$  and output node  $C(s)$  of signal flow graph.

Just for reference, the remaining nodes ( $y_1$  to  $y_9$ ) are labelled in the block diagram. There are nine nodes other than input and output nodes. That is four nodes for four summing points, four nodes for four take-off points and one node for the variable between blocks  $G_1$  and  $G_2$ .

The following figure shows the equivalent signal flow graph.

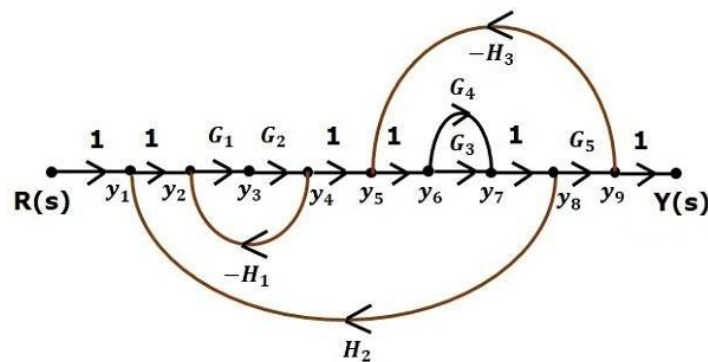

With the help of Mason's gain formula (discussed in the next chapter), you can calculate the transfer function of this signal flow graph. This is the advantage of signal flow graphs. Here, we no need to simplify (reduce) the signal flow graphs for calculating the transfer function.

#### 4.8 Mason's Gain Formula

Let us now discuss the Mason's Gain Formula. Suppose there are 'N' forward paths in a signal flow graph. The gain between the input and the output nodes of a signal flow graph is nothing but the **transfer function** of the system. It can be calculated by using Mason's gain formula.

**Mason's gain formula is**

$$T = C(s)R(s) = \sum_{i=1}^N P_i \Delta_i \Delta$$

Where,

- **C(s)** is the output node
- **R(s)** is the input node
- **T** is the transfer function or gain between  $R(s)$  and  $C(s)$
- **P<sub>i</sub>** is the  $i^{\text{th}}$  forward path gain

$$\Delta = 1 - (\text{sum of all individual loop gains})$$

$$+ (\text{sum of gain products of all possible two non-touching loops})$$

$$- (\text{sum of gain products of all possible three non-touching loops}) + \dots$$

$\Delta_i$  is obtained from  $\Delta$  by removing the loops which are touching the  $i^{\text{th}}$  forward path.

Consider the following signal flow graph in order to understand the basic terminology involved here.

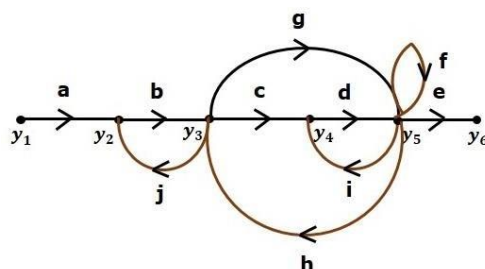

It is a traversal of branches from one node to any other node in the direction of branch arrows. It should not traverse any node more than once.

**Examples** –  $y_2 \rightarrow y_3 \rightarrow y_4 \rightarrow y_5$  and  $y_5 \rightarrow y_3 \rightarrow y_2$

#### Forward Path

The path that exists from the input node to the output node is known as **forward path**.

**Examples** –  $y_1 \rightarrow y_2 \rightarrow y_3 \rightarrow y_4 \rightarrow y_5 \rightarrow y_6$  and  $y_1 \rightarrow y_2 \rightarrow y_3 \rightarrow y_5 \rightarrow y_6$ .

#### Forward Path Gain

It is obtained by calculating the product of all branch gains of the forward path.

**Examples** –  $abcde$  is the forward path gain of  $y_1 \rightarrow y_2 \rightarrow y_3 \rightarrow y_4 \rightarrow y_5 \rightarrow y_6$  and  $abge$  is the forward path gain of  $y_1 \rightarrow y_2 \rightarrow y_3 \rightarrow y_5 \rightarrow y_6$ .

#### Loop

The path that starts from one node and ends at the same node is known as **loop**. Hence, it is a closed path.

**Examples** –  $y_2 \rightarrow y_3 \rightarrow y_2$  and  $y_3 \rightarrow y_5 \rightarrow y_3$ .

#### Loop Gain

It is obtained by calculating the product of all branch gains of a loop.

**Examples** –  $bj$  is the loop gain of  $y_2 \rightarrow y_3 \rightarrow y_2$  and  $gh$  is the loop gain of  $y_3 \rightarrow y_5 \rightarrow y_3$ .

#### Non-touching Loops

These are the loops, which should not have any common node.

**Examples** – The loops,  $y_2 \rightarrow y_3 \rightarrow y_2$  and  $y_4 \rightarrow y_5 \rightarrow y_4$  are non-touching.

**Calculation of Transfer Function using Mason's Gain Formula** Let us consider the same signal flow graph for finding transfer function.

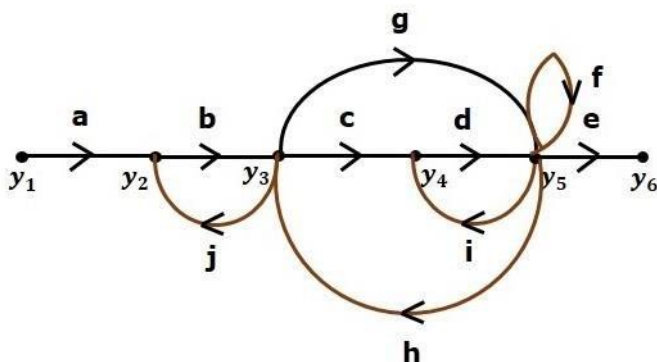

- Number of forward paths,  $N = 2$ .
- First forward path is -  $y_1 \rightarrow y_2 \rightarrow y_3 \rightarrow y_4 \rightarrow y_5 \rightarrow y_6$ .
- First forward path gain,  $p_1 = abcde$ .
- Second forward path is -  $y_1 \rightarrow y_2 \rightarrow y_3 \rightarrow y_5 \rightarrow y_6$ .
- Second forward path gain,  $p_2 = abge$ .
- Number of individual loops,  $L = 5$ .
- Loops are -  $y_2 \rightarrow y_3 \rightarrow y_2$ ,  $y_3 \rightarrow y_5 \rightarrow y_3$ ,  $y_3 \rightarrow y_4 \rightarrow y_5 \rightarrow y_3$ ,  $y_4 \rightarrow y_5 \rightarrow y_4$  and  $y_5 \rightarrow y_5$ .
- Loop gains are -  $l_1 = bj$ ,  $l_2 = gh$ ,  $l_3 = cdh$ ,  $l_4 = di$  and  $l_5 = f$ .
- Number of two non-touching loops = 2.
- First non-touching loops pair is -  $y_2 \rightarrow y_3 \rightarrow y_2$ ,  $y_4 \rightarrow y_5 \rightarrow y_4$ .
- Gain product of first non-touching loops pair,  $l_1 l_4 = bjdi$
- Second non-touching loops pair is -  $y_2 \rightarrow y_3 \rightarrow y_2$ ,  $y_5 \rightarrow y_5$ .
- Gain product of second non-touching loops pair is -  $l_1 l_5 = bjf$

Higher number of (more than two) non-touching loops are not present in this signal flow graph. We know,

$$\Delta = 1 - (\text{sum of all individual loop gains})$$

$$+ (\text{sum of gain products of all possible two non touching loops})$$

$$- (\text{sum of gain products of all possible three non touching loops}) + \dots$$

Substitute the values in the above equation,

$$\Delta = 1 - (bj + gh + cdh + di + f) + (bjdi + bjf) - (0)$$

$$\Rightarrow \Delta = 1 - (bj + gh + cdh + di + f) + bjdi + bjf$$

There is no loop which is non-touching to the first forward path.

So,  $\Delta_1 = 1$ .

Similarly,  $\Delta_2 = 1$ . Since, no loop which is non-touching to the second forward path.

Substitute,  $N = 2$  in Mason's gain formula

$$T = C(s)R(s) = \sum_{i=1}^N P_i \Delta_i \Delta$$

$$T = C(s)R(s) = P_1 \Delta_1 + P_2 \Delta_2 \Delta$$

Substitute all the necessary values in the above equation.

$$T = C(s)R(s) = (abcde)1 + (abge)1 - (bj + gh + cdh + di + f) + bjdi + bjf$$

$$\Rightarrow T = C(s)R(s) = (abcde) + (abge) - (bj + gh + cdh + di + f) + bjdi + bjf$$

Therefore, the transfer function is -

$$T=C(s)R(s)=(abcde)+(abge)1-(bj+gh+cdh+di+f)+bjdi+bjf$$

### 4.9.Simple problems in signal flow graph for network

**Additional**

**Example 7.2** Find the transfer function of the system shown in Fig. E7.4 using Mason's gain rule.

**Fig. E7.4**

**Solution**

**Step 1:** The forward paths of the given SFG are shown below:

(a) First forward path

(b) Second forward path

**Fig. E7.5** Forward paths of Fig. E7.4

$P_1 = G_1 G_2 G_3$  and  $P_2 = G_1 G_3$

**Step 2:**

(a) Loop 1

(a) Loop 2

**Fig. E7.6**

$L_1 = -G_2 H_1$

$L_2 = -G_3 H_2$

**ep 3:** There are no higher order non-touching loops

**ep 4:**  $\Delta = 1 - (L_1 + L_2) = 1 + G_2 G_3 H_1 + G_3 G_2 H_2$

**ep 5:** For  $P_1$ , Loop 1 and Loop 2 touch

$\Delta_1 = 1$

For  $P_1$ ,  
Loop 1 and Loop 2 touches  $P_1$   
 $\Delta_1 = 1$

Step 4:

$$\text{Transfer function} = \frac{P_1 \Delta_1 + P_2 \Delta_2}{\Delta} = \frac{G_1 G_2 G_3 + G_4}{1 + G_1 G_2 H_1 + G_2 G_3 H_2}$$

Example 7.3 The SPFG of a system is shown in Fig. E7.7. Find the transfer function of the system.

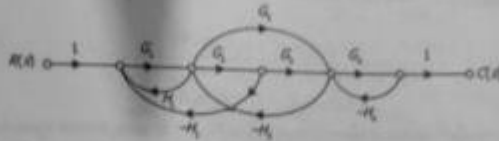

Fig. E7.7

Solution

Step 1: The forward paths of the system are shown in Fig. E7.8



(a) First forward path

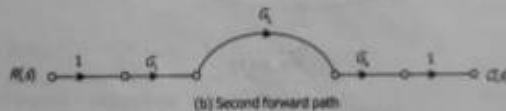

(b) Second forward path

Fig. E7.8 Forward paths of Fig. E7.7

$$P_1 = G_1 G_2 G_3 G_4 \text{ and } P_2 = G_1 G_2 G_3$$

Step 2: The loops of Fig. E7.7 are shown below:

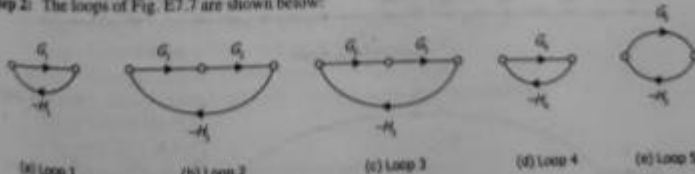

(a) Loop 1

(b) Loop 2

(c) Loop 3

(d) Loop 4

(e) Loop 5

Fig. E7.9

Step 3:  $L_1 = -G_1 H_1$ ,  $L_2 = -G_2 H_2$ ,  $L_3 = -G_2 H_3$ ,  $L_4 = -G_1 H_4$  and  $L_5 = -G_3 H_5$ ,  
Loop 1 and Loop 4, Loop 2 and Loop 4 are non-touching.  
 $L_{12} = \text{Loop 1} \times \text{Loop 4} = G_1 G_2 H_1 H_4$  and  $L_{24} = \text{Loop 2} \times \text{Loop 4} = G_2 G_3 H_2 H_4$

## Short questions

1 what do you mean by block diagram

Ans A block diagram is a diagram of a system in which the principal parts or functions are represented by blocks connected by lines that show the relationships of the blocks. [

2-what do you mean by summing point in feedback control system

Ans-the summing point is represented with a circle having cross inside it. It has two or more input and single output. It produces the algebraic sum of inputs. It also performs the summation or subtraction or combination of summation and subtraction of inputs based on the polarity of the inputs

3-what is signal flow graph

*A graphical method of representing the control system using the linear algebraic equations is known as the signal flow graph. It is abbreviated as SFG. This graph basically signifies how the signal flows in a system.*

#### LONG QUESTIONS

*1-state the rules of block diagram reduction?*

*2-Write down procedure of reduction of block diagram?*

*3-write down the steps for solving signal flow graph?*

*4-write down the steps for **finding transfer function of a system through masn gain formula?***

## CHAPTER-5 TIME RESPONSE ANALYSIS

### **TIME RESPONSE ANALYSIS**

#### **5.1.What is Time Response?**

If the output of control system for an input varies with respect to time, then it is called the **time response** of the control system. The time response consists of two parts.

- Transient response
- Steady state response

The response of control system in time domain is shown in the following figure.

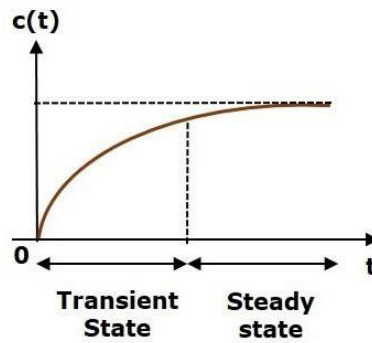

Here, both the transient and the steady states are indicated in the figure. The responses corresponding to these states are known as transient and steady state responses.

Mathematically, we can write the time response  $c(t)$  as

$$c(t) = c_{tr}(t) + c_{ss}(t)$$

Where,

- $c_{tr}(t)$  is the transient response
- $c_{ss}(t)$  is the steady state response

### Transient Response

After applying input to the control system, output takes certain time to reach steady state. So, the output will be in transient state till it goes to a steady state. Therefore, the response of the control system during the transient state is known as **transient response**.

The transient response will be zero for large values of 't'. Ideally, this value of 't' is infinity and practically, it is five times constant.

Mathematically, we can write it as

$$\lim_{t \rightarrow \infty} c_{tr}(t) = 0$$

## Steady state Response

The part of the time response that remains even after the transient response has zero value for large values of 't' is known as **steady state response**. This means, the transient response will be zero even during the steady state.

## 5.2 STANDARD TEST SIGNALS

The standard test signals are impulse, step, ramp and parabolic. These signals are used to know the performance of the control systems using time response of the output.

### Unit Impulse Signal

A unit impulse signal,  $\delta(t)$  is defined as

$$\delta(t) = 0 \text{ for } t \neq 0$$

$$\int_{0^-}^{0^+} \delta(t) dt = 1$$

The following figure shows unit impulse signal.

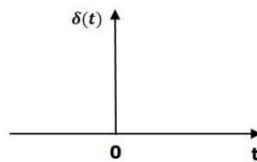

So, the unit impulse signal exists only at 't' is equal to zero. The area of this signal under small interval of time around 't' is equal to one. The value of unit impulse signal is zero for all other values of 't'.

### Unit Step Signal

A unit step signal,  $u(t)$  is defined as

$$u(t) = 1; t \geq 0$$

$$= 0; t < 0$$

Following figure shows unit step signal.

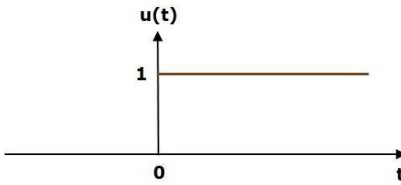

So, the unit step signal exists for all positive values of 't' including zero. And its value is one during this interval. The value of the unit step signal is zero for all negative values of 't'.

### Unit Ramp Signal

A unit ramp signal,  $r(t)$  is defined as

$$r(t) = t; t \geq 0$$

$$= 0; t < 0$$

We can write unit ramp signal,  $r(t)$  in terms of unit step signal,  $u(t)$  as

$$r(t) = tu(t)$$

Following figure shows unit ramp signal.

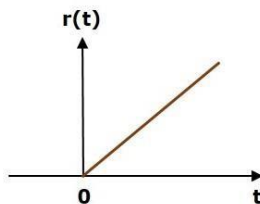

So, the unit ramp signal exists for all positive values of 't' including zero. And its value increases linearly with respect to 't' during this interval. The value of unit ramp signal is zero for all negative values of 't'.

### Unit Parabolic Signal

A unit parabolic signal,  $p(t)$  is defined as,

$$p(t) = t^2; t \geq 0$$

$$= 0; t < 0$$

We can write unit parabolic signal,  $p(t)$  in terms of the unit step signal,  $u(t)$  as,

$$p(t) = t^2u(t)$$

The following figure shows the unit parabolic signal.

The following figure shows the unit parabolic signal.

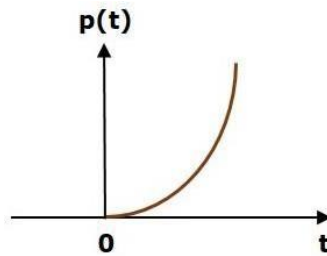

So, the unit parabolic signal exists for all the positive values of 't' including zero. And its value increases non-linearly with respect to 't' during this interval. The value of the unit parabolic signal is zero for all the negative values of 't'.

### 5.3 Response of the First Order System

In this chapter, let us discuss the time response of the first order system. Consider the following block diagram of the closed loop control system. Here, an open loop transfer function,  $\frac{1}{sT}$  is connected with a unity negative feedback.

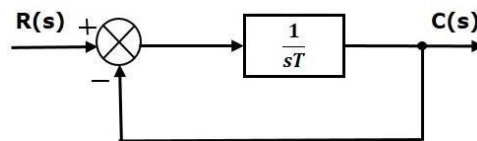

We know that the transfer function of the closed loop control system has unity negative feedback as,

$$C(s)R(s) = G(s)1 + G(s)C(s)R(s) = G(s)1 + G(s)$$

Substitute,  $G(s) = \frac{1}{sT}$  in the above equation.

$$C(s)R(s) = \frac{1}{sT}1 + \frac{1}{sT}C(s)R(s) = \frac{1}{sT} + \frac{1}{sT}C(s)R(s)$$

The power of s is one in the denominator term. Hence, the above transfer function is of the first order and the system is said to be the **first order system**.

We can re-write the above equation as

$$C(s) = (1 + sT)R(s)$$

Where,

- **C(s)** is the Laplace transform of the output signal  $c(t)$ ,
- **R(s)** is the Laplace transform of the input signal  $r(t)$ , and
- **T** is the time constant.

Follow these steps to get the response (output) of the first order system in the time domain.

- Take the Laplace transform of the input signal  $r(t)$ .
- Consider the equation,  $C(s) = (1 + sT)R(s)$
- Substitute  $R(s)$  value in the above equation.
- Do partial fractions of  $C(s)$  if required.
- Apply inverse Laplace transform to  $C(s)$ .
- In the previous chapter, we have seen the standard test signals like impulse, step, ramp and parabolic. Let us now find out the responses of the first order system for each input, one by one. The name of the response is given as per the name of the input signal. For example, the response of the system for an impulse input is called as impulse response.

- Step Response of First Order System

- Consider the **unit step signal** as an input to first order system.

- So,  $r(t) = u(t)$

- Apply Laplace transform on both the sides.

- $R(s) = \frac{1}{s}$

- 

- Consider the equation,  $C(s) = (1 + sT)R(s)$

- Substitute,  $R(s) = \frac{1}{s}$  in the above equation.

- $C(s) = (1 + sT) \left(\frac{1}{s}\right) = \frac{1 + sT}{s}$

- 

- Do partial fractions of  $C(s)$ .

- 

- $C(s) = \frac{1 + sT}{s} = \frac{A}{s} + \frac{B}{s + \frac{1}{T}}$

- 

- $\Rightarrow \frac{1 + sT}{s} = \frac{A}{s} + \frac{B}{s + \frac{1}{T}} \Rightarrow 1 + sT = A \left( \frac{s + \frac{1}{T}}{s + \frac{1}{T}} \right) + B \left( \frac{s}{s + \frac{1}{T}} \right)$

- 

- On both the sides, the denominator term is the same. So, they will get cancelled by each other. Hence, equate the numerator terms.

- $1 + sT = A \left( \frac{s + \frac{1}{T}}{s + \frac{1}{T}} \right) + B \left( \frac{s}{s + \frac{1}{T}} \right)$

-

- By equating the constant terms on both the sides, you will get  $A = 1$ . Substitute,  $A = 1$  and equate the coefficient of the  $s$  terms on both the sides.

- 

- $0 = T + B \Rightarrow B = -T$

- 

- Substitute,  $A = 1$  and  $B = -T$  in partial fraction expansion of  $C(s)$ 
  - $C(s) = \frac{1}{s - T} + \frac{B}{s + 1} = \frac{1}{s - T} - \frac{T}{s + 1}$

- 

- $\Rightarrow C(s) = \frac{1}{s - T} - \frac{T}{s + 1}$

- 

- Apply inverse Laplace transform on both the sides.

- $c(t) = (1 - e^{-t/T})u(t)$

- The **unit step response**,  $c(t)$  has both the transient and the steady state terms. The transient term in the unit step response is -

- $c(t) = -e^{-t/T}u(t)$

-

- The steady state term in the unit step response is –
- The transient term in the unit step response is -
  - $c_{tr}(t) = -e^{-(\zeta/\tau)}u(t)$
  - $c_{tr}(t) = -e^{-(t/T)}u(t)$
- 
- The following figure shows the unit step response.
- 

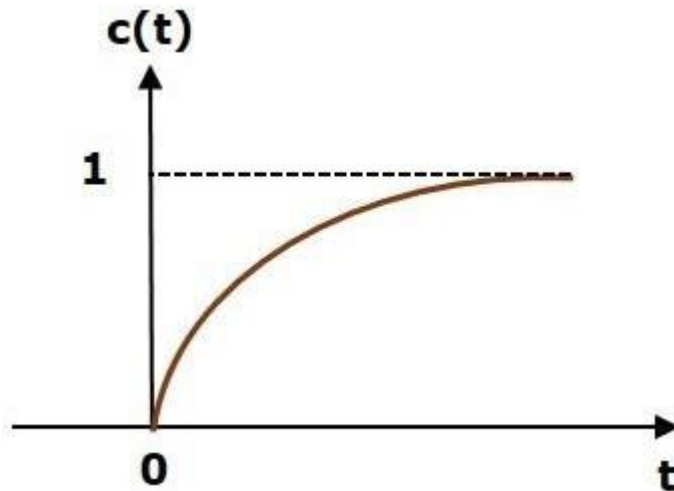

- 
- 
- 
- The value of the **unit step response**,  $c(t)$  is zero at  $t = 0$  and for all negative values of  $t$ . It is gradually increasing from zero value and finally reaches to one in steady state. So, the steady state value depends on the magnitude of the input.

- *Response of Second Order System*

- In this chapter, let us discuss the time response of second order system. Consider the

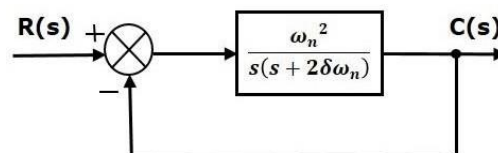

following block diagram of closed loop control system. Here, an open loop transfer function,  $\frac{\omega_n^2}{s(s+2\delta\omega_n)}$  is connected with a unity negative feedback.

- 
- 
- We know that the transfer function of the closed loop control system having unity negative feedback as

$$\frac{C(s)}{R(s)} = \frac{G(s)}{1 + G(s)}$$

•

$$\frac{C(s)}{R(s)} = \frac{\left(\frac{\omega_n^2}{s(s+2\delta\omega_n)}\right)}{1 + \left(\frac{\omega_n^2}{s(s+2\delta\omega_n)}\right)} = \frac{\omega_n^2}{s^2 + 2\delta\omega_n s + \omega_n^2}$$

•

- The power of 's' is two in the denominator term. Hence, the above transfer function is of the second order and the system is said to be the **second order system**.

$$s^2 + 2\delta\omega_n s + \omega_n^2 = 0$$

- The characteristic equation is

$$\Rightarrow s = -\delta\omega_n \pm \omega_n \sqrt{\delta^2 - 1}$$

The roots of characteristic equation are -

- The two roots are imaginary when  $\delta = 0$ .
- The two roots are real and equal when  $\delta = 1$ .
- The two roots are real but not equal when  $\delta > 1$ .
- The two roots are complex conjugate when  $0 < \delta < 1$ .

### 5.4.1

## Step Response of Second Order System

Consider the unit step signal as an input to the second order system.

Laplace transform of the unit step signal is,

$$R(s) = \frac{1}{s}$$

We know the transfer function of the second order closed loop control system is,

$$\frac{C(s)}{R(s)} = \frac{\omega_n^2}{s^2 + 2\delta\omega_n s + \omega_n^2}$$

### Case 1: $\delta = 0$

Substitute,  $\delta = 0$  in the transfer function.

$$\begin{aligned} \frac{C(s)}{R(s)} &= \frac{\omega_n^2}{s^2 + \omega_n^2} \\ \Rightarrow C(s) &= \left( \frac{\omega_n^2}{s^2 + \omega_n^2} \right) R(s) \end{aligned}$$

Substitute,  $R(s) = \frac{1}{s}$  in the above equation.

### 5.4.2 Time Domain Specifications

In this chapter, let us discuss the time domain specifications of the second order system. The step response of the second order system for the underdamped case is shown in the following figure.

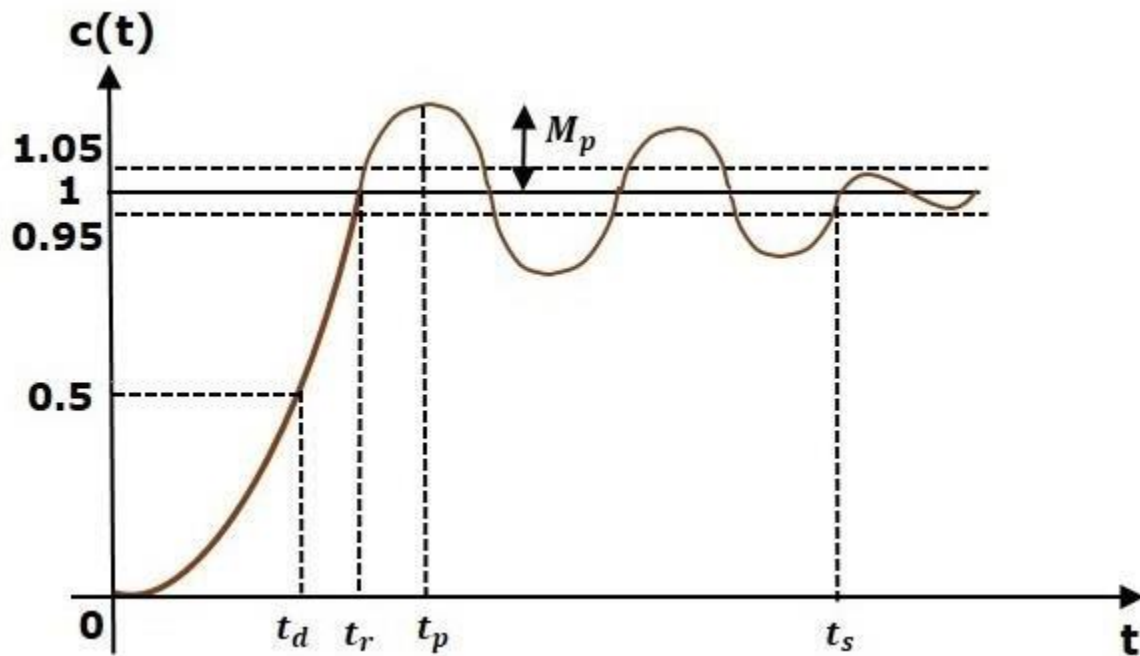

All the time domain specifications are represented in this figure. The response up to the settling time is known as transient response and the response after the settling time is known as steady state response.

Delay Time

It is the time required for the response to reach **half of its final value** from the zero instant. It is denoted by  $t_{dtd}$ . Consider the step response of the second order system for  $t \geq 0$ , when ' $\delta$ ' lies between zero and one.

$$c(t) = 1 - \left( \frac{e^{-\delta\omega_n t}}{\sqrt{1 - \delta^2}} \right) \sin(\omega_d t + \theta)$$

The final value of the step response is one.

Therefore, at  $t=t_d$ , the value of the step response will be 0.5. Substitute, these values in the above

$$c(t_d) = 0.5 = 1 - \left( \frac{e^{-\delta\omega_n t_d}}{\sqrt{1-\delta^2}} \right) \sin(\omega_d t_d + \theta)$$

$$\Rightarrow \left( \frac{e^{-\delta\omega_n t_d}}{\sqrt{1-\delta^2}} \right) \sin(\omega_d t_d + \theta) = 0.5$$

equation.

By using linear approximation, you will get the **delay time  $t_d$**  as

$$t_d = \frac{1 + 0.7\delta}{\omega_n}$$

## Rise Time

It is the time required for the response to rise from **0% to 100% of its final value**. This is applicable for the **under-damped systems**. For the over-damped systems, consider the duration from 10% to 90% of the final value. Rise time is denoted by  $t_r$ .

$$c(t) = 1 - \left( \frac{e^{-\delta\omega_n t}}{\sqrt{1-\delta^2}} \right) \sin(\omega_d t + \theta)$$

$$c(t_2) = 1 = 1 - \left( \frac{e^{-\delta\omega_n t_2}}{\sqrt{1-\delta^2}} \right) \sin(\omega_d t_2 + \theta)$$

$$\Rightarrow \left( \frac{e^{-\delta\omega_n t_2}}{\sqrt{1-\delta^2}} \right) \sin(\omega_d t_2 + \theta) = 0$$

$$\Rightarrow \sin(\omega_d t_2 + \theta) = 0$$

$$\Rightarrow \omega_d t_2 + \theta = \pi$$

$$\Rightarrow t_2 = \frac{\pi - \theta}{\omega_d}$$

Substitute  $t_1$  and  $t_2$  values in the following equation of **rise time**,

$$t_r = t_2 - t_1$$

$$\therefore t_r = \frac{\pi - \theta}{\omega_d}$$

From above equation, we can conclude that the rise time  $t_r$  and the damped frequency  $\omega_d$  are inversely proportional to each other.

## Peak Time

It is the time required for the response to reach the **peak value** for the first time. It is denoted by  $t_{pt}$ . At  $t=t_{pt}$ , the first derivative of the response is zero.

We know the step response of second order system for under-damped case is

Peak Overshoot

Peak overshoot  $M_p$  is defined as the deviation of the response at peak time from the final value of response. It is also called the **maximum overshoot**.

Mathematically, we can write it as

$$M_p = \frac{c(t_p) - c(\infty)}{c(\infty)}$$

Where,

$c(t_p)$  is the peak value of the response.

$c(\infty)$  is the final (steady state) value of the response.

$$c(t_p) = 1 - \left( \frac{e^{-\delta\omega_n t_p}}{\sqrt{1-\delta^2}} \right) \sin(\omega_d t_p + \theta)$$

Substitute,  $t_p = \frac{\pi}{\omega_d}$  in the right hand side of the above equation.

$$c(t_p) = 1 - \left( \frac{e^{-\delta\omega_n \left(\frac{\pi}{\omega_d}\right)}}{\sqrt{1-\delta^2}} \right) \sin\left(\omega_d \left(\frac{\pi}{\omega_d}\right) + \theta\right)$$

$$\Rightarrow c(t_p) = 1 - \left( \frac{e^{-\left(\frac{\delta\pi}{\sqrt{1-\delta^2}}\right)}}{\sqrt{1-\delta^2}} \right) (-\sin(\theta))$$

We know that

$$\sin(\theta) = \sqrt{1-\delta^2}$$

So, we will get  $c(t_p)$  as

$$c(t_p) = 1 + e^{-\left(\frac{\delta\pi}{\sqrt{1-\delta^2}}\right)}$$

### Settling time

It is the time required for the response to reach the steady state and stay within the specified tolerance bands around the final value. In general, the tolerance bands are 2% and 5%. The settling time is denoted by  $t_{sts}$ .

The settling time for 5% tolerance band is -

$$t_s = \frac{3}{\delta\omega_n} = 3\tau$$

The settling time for 2% tolerance band is -

$$t_s = \frac{4}{\delta\omega_n} = 4\tau$$

Where,  $\tau$  is the time constant and is equal to  $\frac{1}{\delta\omega_n}$ .

Time domain specification	Formula	Substitution of values in Formula	Final value
Delay time	$t_d = 1 + 0.7\delta\omega_n$	$t_d = 1 + 0.7(0.5)$	$t_d = 0.675$ sec
Rise time	$t_r = \pi - \theta$	$t_r = \pi - (\pi/3)$	$t_r = 1.207$ sec
Peak time	$t_p = \pi/\omega_d$	$t_p = \pi/1.732$	$t_p = 1.813$ sec
% Peak overshoot	$\%M_p = \left( \frac{1}{\sqrt{1 - \delta^2}} e^{-\delta\pi/\sqrt{1 - \delta^2}} \right) \times 100\%$	$\%M_p = \left( \frac{1}{\sqrt{1 - (0.5)^2}} e^{-(0.5\pi/\sqrt{1 - (0.5)^2})} \right) \times 100\%$	$\%M_p = 16.32\%$
Settling time for 2% tolerance band	$t_s = 4/\delta\omega_n$	$t_s = 4/(0.5)$	$t_s = 4$ sec

### 5.4.3 Control Systems - Steady State Errors

The deviation of the output of control system from desired response during steady state is known as **steady state error**. It is represented as  $e_{ss}$ . We can find steady state error using the final value theorem as follows.

$$e_{ss} = \lim_{t \rightarrow \infty} e(t) = \lim_{s \rightarrow 0} sE(s)$$

Where,

$E(s)$  is the Laplace transform of the error signal,  $e(t)$

Let us discuss how to find steady state errors for unity feedback and non-unity feedback control systems one by one.

## Steady State Errors for Unity Feedback Systems

Consider the following block diagram of closed loop control system, which is having unity negative feedback.

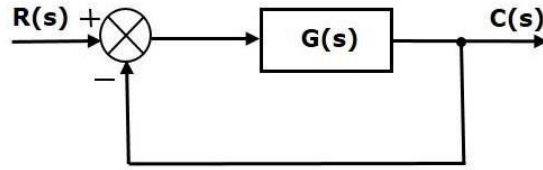

$$\frac{C(s)}{R(s)} = \frac{G(s)}{1 + G(s)}$$

$$\Rightarrow C(s) = \frac{R(s)G(s)}{1 + G(s)}$$

The output of the summing point is -

$$E(s) = R(s) - C(s)$$

Substitute  $C(s)$  value in the above equation.

$$E(s) = R(s) - \frac{R(s)G(s)}{1 + G(s)}$$

$$\Rightarrow E(s) = \frac{R(s) + R(s)G(s) - R(s)G(s)}{1 + G(s)}$$

$$\Rightarrow E(s) = \frac{R(s)}{1 + G(s)}$$

Substitute  $E(s)$  value in the steady state error formula

$$e_{ss} = \lim_{s \rightarrow 0} \frac{sR(s)}{1 + G(s)}$$

Input signal	Steady state error $e_{ss}$	Error constant
unit step signal	$\frac{1}{1+k_p}$	$K_p = \lim_{s \rightarrow 0} G(s)$
unit ramp signal	$\frac{1}{K_v}$	$K_v = \lim_{s \rightarrow 0} sG(s)$

Input signal	Error constant	Steady state error
$r_1(t) = 5u(t)$	$K_p = \lim_{s \rightarrow 0} G(s) = \infty$	$e_{ss1} = \frac{5}{1+K_p} = 0$
$r_2(t) = 2tu(t)$	$K_v = \lim_{s \rightarrow 0} sG(s) = \infty$	$e_{ss2} = \frac{2}{K_v} = 0$
$r_3(t) = t^2u(t)$	$K_a = \lim_{s \rightarrow 0} s^2G(s) = 1$	$e_{ss3} = \frac{1}{K_a} = 1$

We will get the overall steady state error, by adding the above three steady state errors.

$$e_{ss} = e_{ss1} + e_{ss2} + e_{ss3} = 0 + 0 + 1 = 1$$

$$\Rightarrow e_{ss} = 0 + 0 + 1 = 1$$

## 5.5 Types of control system (type 0, type 1, type 2 system)

### Step input to a Type 0 system:

From my previous post, we already know the steady state error ' $e_{ss}$ ' for a step input is

$$e_{ss} = \frac{A}{1+k_p}$$

$$\text{where } k_p = \lim_{s \rightarrow 0} G(s)H(s) = \lim_{s \rightarrow 0} \frac{k(1+T_{z1}s)(1+T_{z2}s)\dots\dots\dots}{s^0(1+T_{p1}s)(1+T_{p2}s)\dots\dots\dots}$$

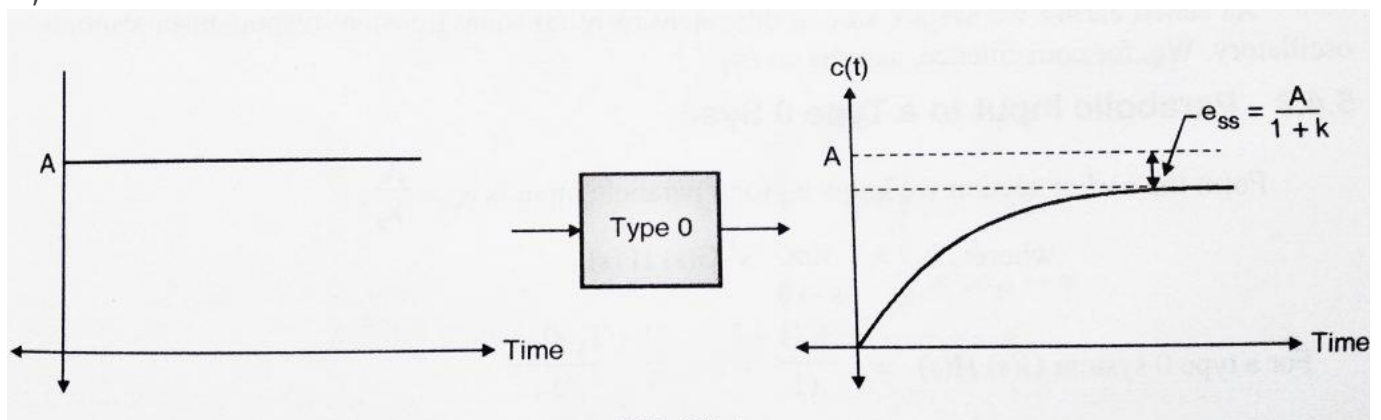

$$k_p = \frac{k(1)(1)\dots}{s^0(1)(1)\dots}$$

$$= k,$$

$$e_{ss} = \frac{A}{1+k_p} = \frac{A}{1+k},$$

Hence when a type 0 system is subjected to a step input, we get a constant steady state error.

### Step Input to Type 1 System:

we already know 'e<sub>ss</sub>' for a step input is

$$e_{ss} = \frac{A}{1+k_p} \quad \text{where} \quad k_p = \lim_{s \rightarrow 0} G(s)H(s) = \lim_{s \rightarrow 0} \frac{k(1+T_{z1}s)(1+T_{z2}s)\dots}{s^1(1+T_{p1}s)(1+T_{p2}s)\dots},$$

$$k_p = \frac{k(1)(1)\dots}{s^1(1)(1)\dots} = \infty \text{ (infinity)},$$

$$e_{ss} = \frac{A}{1+k_p} = \frac{A}{1+\infty} = 0,$$

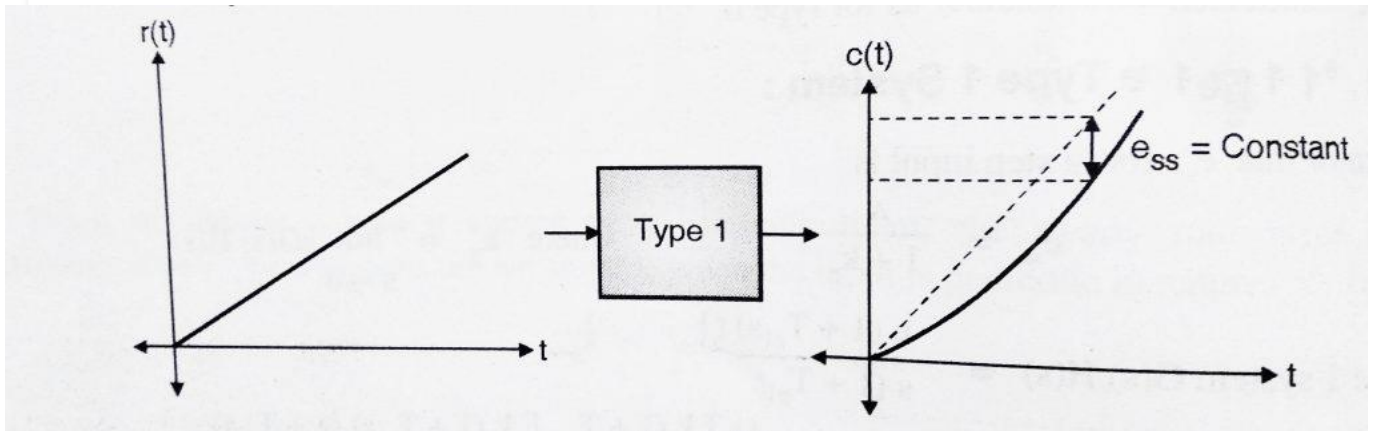

Hence when a type 1 system is subjected to a step input, we get steady state error i.e.  $e_{ss} = 0$ . Hence we can conclude that type 1 systems are excellent for step inputs as steady state error is 0.

### Step Input to a type 2 System

we already know 'e<sub>ss</sub>' for a step input is

$$e_{ss} = \frac{A}{1+k_p} \quad \text{where } k_p = \lim_{s \rightarrow 0} G(s)H(s) = \lim_{s \rightarrow 0} \frac{k(1+T_{z1}s)(1+T_{z2}s)\dots\dots\dots}{s^2(1+T_{p1}s)(1+T_{p2}s)\dots\dots\dots} = 0 \quad ,$$

$$k_p = \frac{k(1)(1)\dots\dots}{s^2(1)(1)\dots\dots} = \infty \text{ (infinity) } ,$$

$$e_{ss} = \frac{A}{1+k_p} = \frac{A}{1+\infty} = 0 \quad ,$$

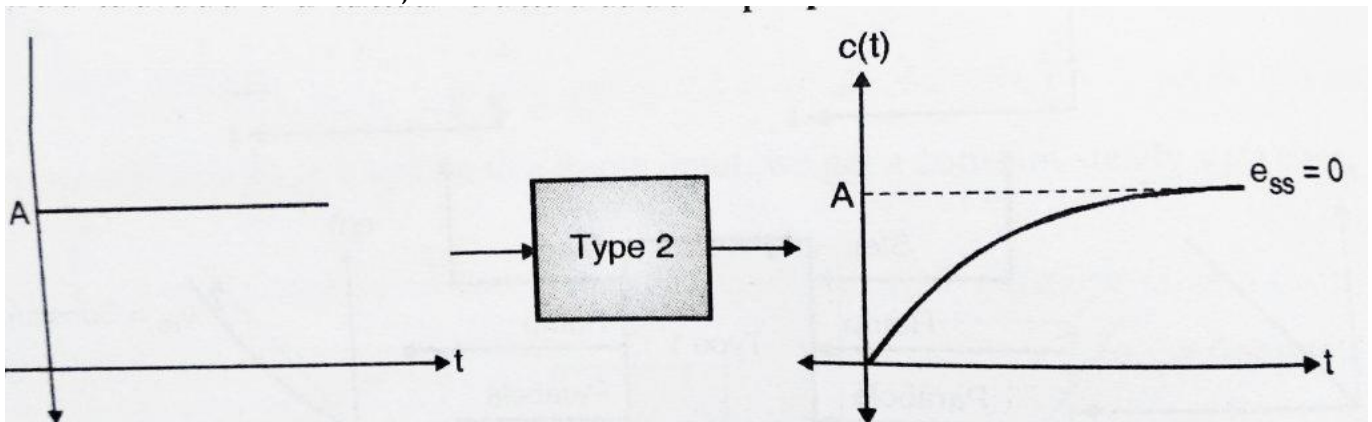

Hence when a type 2 system is subjected to a step input, we get steady state error i.e. = 0. Hence we can conclude that type 2 systems are excellent for step inputs as steady state error is 0.

### Ramp input to a Type 0 system:

From my previous post , we already know the steady state error 'e<sub>ss</sub>' for a ramp input is

$$e_{ss} = \frac{A}{k_v}$$

$$\text{where } k_v = \lim_{s \rightarrow 0} sG(s)H(s) = \lim_{s \rightarrow 0} \frac{sk(1+T_{z1}s)(1+T_{z2}s)\dots\dots\dots}{s^0(1+T_{p1}s)(1+T_{p2}s)\dots\dots\dots} = 0,$$

$$k_v = \frac{sk(1)(1)\dots\dots}{s^0(1)(1)\dots\dots} = 0,$$

$$e_{ss} = \frac{A}{k_v} = \frac{A}{0} = \infty \text{ (infinity) } ,$$

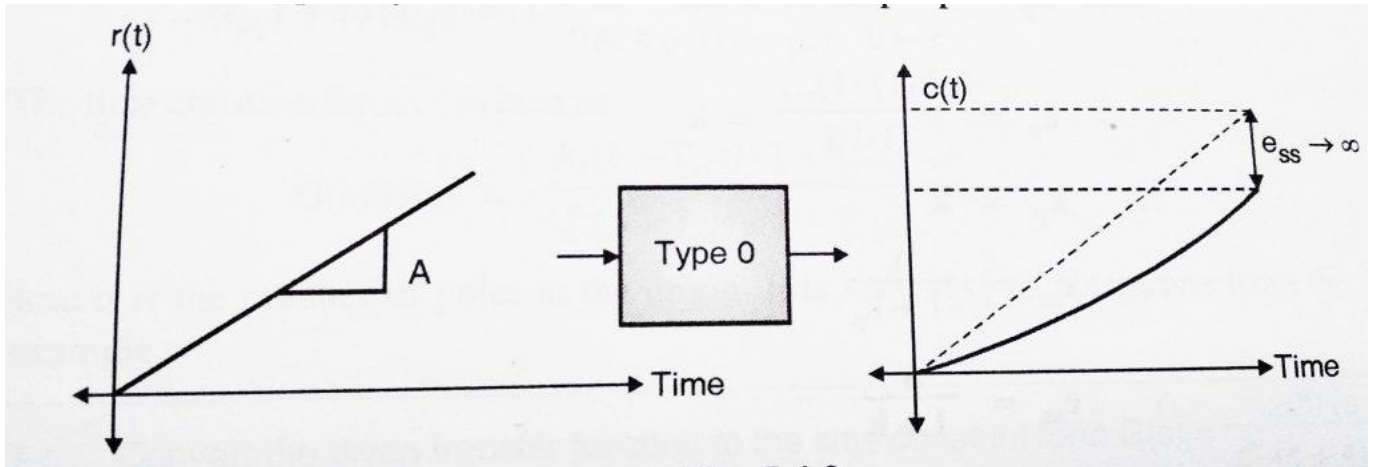

Hence when we subject a type 0 system to a ramp input, the steady state error increases continuously.

### Ramp input to a Type 1 System

$$e_{ss} = \frac{A}{k_v}$$

$$\text{where } k_v = \lim_{s \rightarrow 0} sG(s)H(s) = \lim_{s \rightarrow 0} \frac{sk(1+T_{z1}s)(1+T_{z2}s)\dots\dots\dots}{s^1(1+T_{p1}s)(1+T_{p2}s)\dots\dots\dots}$$

$$k_v = \frac{sk(1)(1)\dots\dots}{s^1(1)(1)\dots\dots} = k,$$

$$e_{ss} = \frac{A}{k_v} = \frac{A}{k} = \text{constant},$$

Hence when we subject a type 1 system to a ramp input, the steady state error is constant.

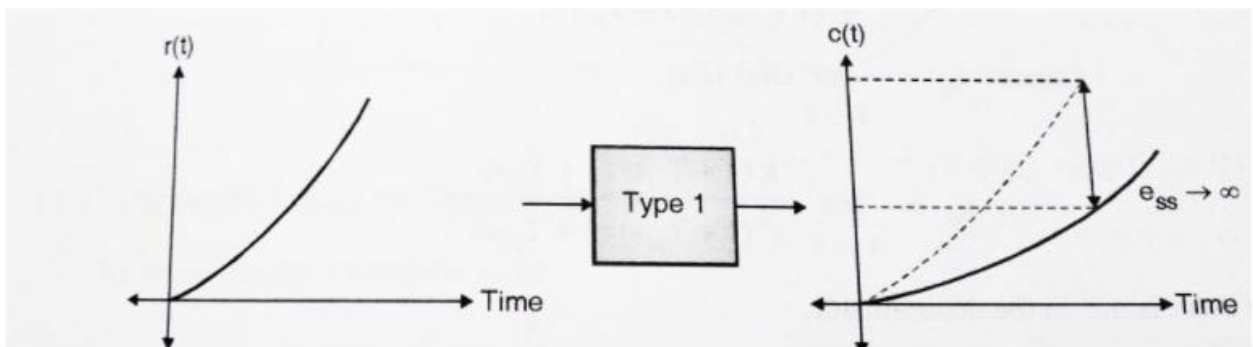

### 3.2 Ramp input to a Type 2 System

we already know 'e<sub>ss</sub>' for a ramp input is

$$e_{ss} = \frac{A}{k_v} \text{ where ,}$$

$$k_v = \lim_{s \rightarrow 0} sG(s)H(s) = \lim_{s \rightarrow 0} \frac{sk(1 + T_{z1}s)(1 + T_{z2}s)\dots\dots\dots}{s^2(1 + T_{p1}s)(1 + T_{p2}s)\dots\dots\dots}$$

$$k_v = \frac{sk(1)(1)\dots\dots}{s^2(1)(1)\dots\dots} = \infty,$$

$$e_{ss} = \frac{A}{k_v} = \frac{A}{\infty} = 0,$$

Hence when we subject a type 2 system to a ramp input, the steady state error is 0.

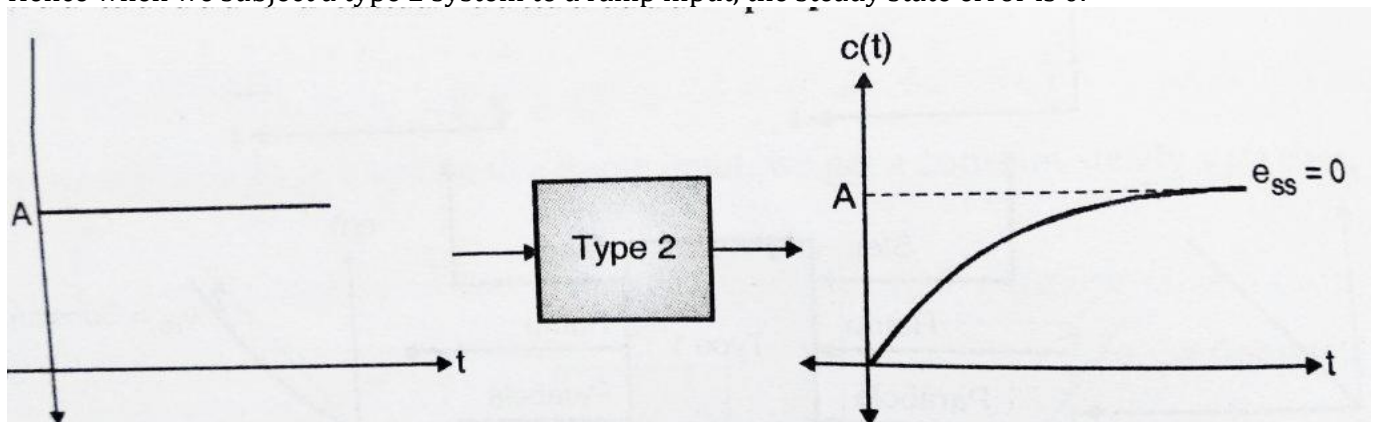

**Parabolic input to a Type 0 system:**

we already know 'e<sub>ss</sub>' for a parabolic input is

$$e_{ss} = \frac{A}{k_a} \quad \text{where ,}$$

$$k_a = \lim_{s \rightarrow 0} (s^2 G(s)H(s)) = \lim_{s \rightarrow 0} \frac{s^2 k(1 + T_{z1}s)(1 + T_{z2}s) \dots \dots \dots}{s^2(1 + T_{p1}s)(1 + T_{p2}s) \dots \dots \dots}$$

$$k_a = \frac{s^2 k(1)(1) \dots \dots}{s^2(1)(1) \dots \dots} = k ,$$

$$e_{ss} = \frac{A}{k_a} = \frac{A}{k} = \text{const} ,$$

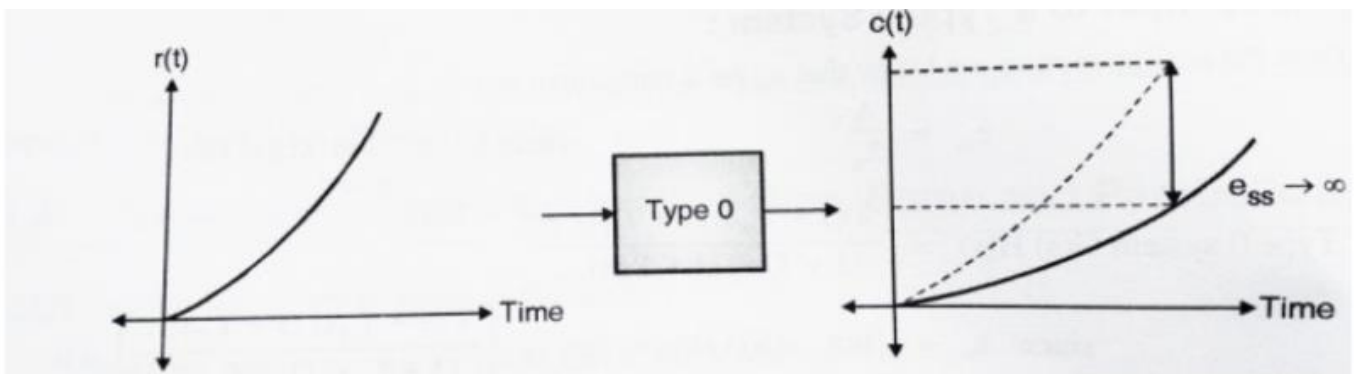

ence when we subject a type 0 system to a parabolic input, the steady state error increases continuously.  
 ence type 0 system are not suitable when the input is parabolic in nature.

ow we shall shift our focus to type 1 systems:

'Type 1' system is given by

$$'(s)H(s) = \lim_{s \rightarrow 0} \frac{k(1+T_{z1}s)(1+T_{z2}s) \dots \dots \dots}{s^1(1+T_{p1}s)(1+T_{p2}s) \dots \dots \dots} = 0 \quad \text{(one pole at origin)}$$

### Parabolic Input to a Type 1 System:

we already know 'e<sub>ss</sub>' for a parabolic input is

$$e_{ss} = \frac{A}{k_a} \quad \text{where} \quad k_a = \lim_{s \rightarrow 0} s^2 G(s)H(s) = \lim_{s \rightarrow 0} \frac{s^2 k(1+T_{z1}s)(1+T_{z2}s)\dots\dots\dots}{s^1(1+T_{p1}s)(1+T_{p2}s)\dots\dots\dots} = 0 ,$$

$$k_a = \frac{s^2 k(1)(1)\dots}{s^1(1)(1)\dots} = 0 ,$$

$$e_{ss} = \frac{A}{k_a} = \frac{A}{k} = \infty(\text{infinity}) ,$$

Hence when we subject a type 1 system to a parabolic input, the steady state error increases continuously. Hence type 1 system are not suitable when the input is parabolic in nature.

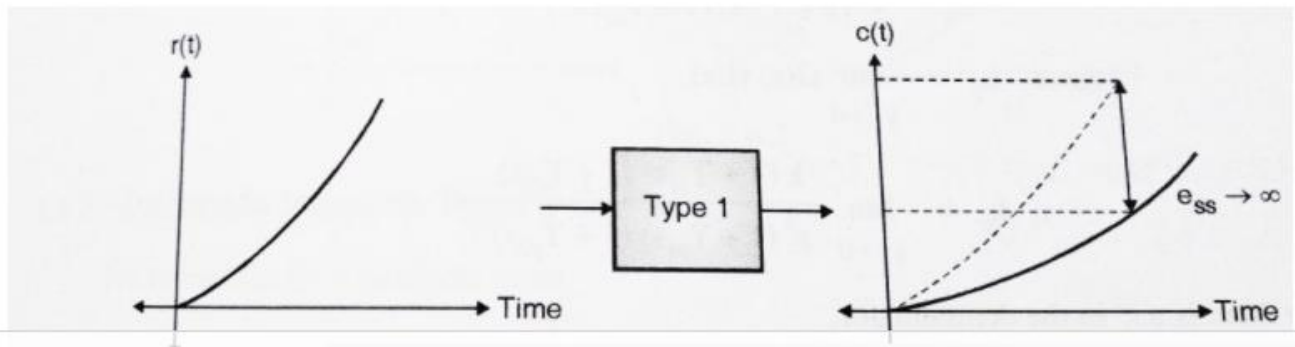

### Parabolic Input to a Type 2 System:

we already know 'e<sub>ss</sub>' for a parabolic input is

$$e_{ss} = \frac{A}{k_a} \quad \text{where ,}$$

$$k_a = \lim_{s \rightarrow 0} (s^2 G(s)H(s)) = \lim_{s \rightarrow 0} \frac{s^2 k(1 + T_{z1}s)(1 + T_{z2}s) \dots \dots \dots}{s^2(1 + T_{p1}s)(1 + T_{p2}s) \dots \dots \dots}$$

$$k_a = \frac{s^2 k(1)(1) \dots \dots}{s^2(1)(1) \dots \dots} = k ,$$

$$e_{ss} = \frac{A}{k_a} = \frac{A}{k} = \text{const ,}$$

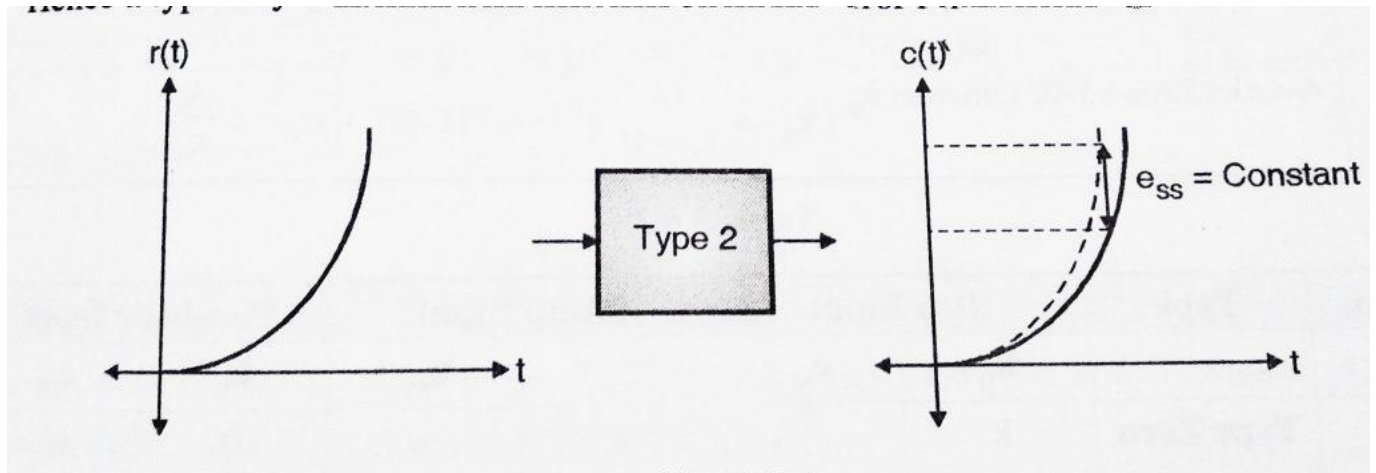

Hence when we subject a type 2 system to a parabolic input, the steady state error is constant. Hence we can conclude that Type 2 systems are excellent for step and ramp signals and gives constant error for parabolic inputs.

## Error of different types of input

Sr no	Type	Step input		Ramp input		Parabolic Input	
		$k_p$	$e_{ss}$	$k_v$	$e_{ss}$	$k_a$	$e_{ss}$
1	Type 0	k	$\frac{A}{1+k}$	0	$\infty$	0	$\infty$
2	Type 1	$\infty$	0	k	$\frac{A}{k}$	0	$\infty$
3	Type 2	$\infty$	0	$\infty$	0	k	$\frac{A}{k}$

### 5.6.Effect of adding poles and zeros to the transfer function

To understand over damped, under damped and Critical damped in control system, Let we take the closed loop transfer function in generic form and analysis that to find out different condition Over damped, underdamped and Critical damped in control system.

$$T(s) = \frac{\omega_n^2}{s^2 + 2\delta\omega_n s + \omega_n^2}$$

Now we know that the transient response of any system depends on the poles of the transfer function T(s). And as we know that the roots of the denominator polynomial in s of T(s) are the poles of the transfer function. So in our case the denominator polynomial of T(s), is

$$D(s) = s^2 + 2\delta\omega_n s + \omega_n^2$$

is known as the *characteristic polynomial* of the system and  $D(s) = 0$  is known as the *characteristic equation* of the system.

So The poles of T (s), or, the roots of the characteristic equation we can get by

$$s^2 + 2\delta\omega_n s + \omega_n^2 = 0$$

are given by,

$$s_{1,2} = \frac{-2\delta\omega_n \pm \sqrt{4\delta^2\omega_n^2 - 4\omega_n^2}}{2}$$

$$= -\delta\omega_n \pm j\omega_n\sqrt{1-\delta^2} \quad (\text{assuming } \delta < 1)$$

$$= -\delta\omega_n \pm j\omega_d$$

Where  $\omega_d$  is known as the *damped natural frequency* of the system.

Now If  $\delta > 1$ , the two roots  $s_1$  and  $s_2$  are real and we have an over damped system.

If  $\delta = 1$ , the system is known as a *critically damped system*.

The more common case of  $0 < 1$  is known as the *under damped system*.

Now if we go for step responds of different second order systems then we can see

Step response of an under damped second order system.

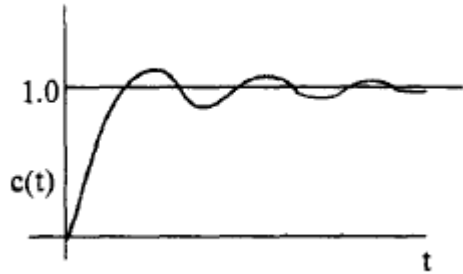

Step response of a critically damped second order system.

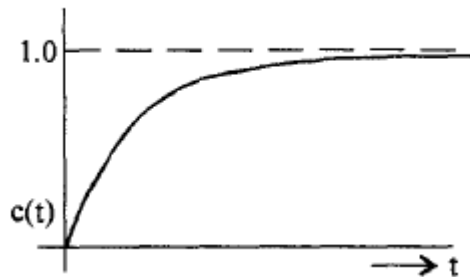

Step response of an over damped second order system.

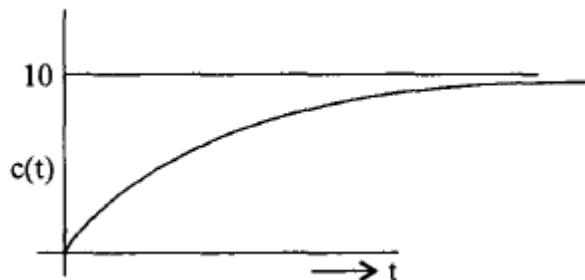

### 5.7. Response with P,PI,PD,PID controller

Process controls are necessary for designing safe and productive plants. A variety of process controls are used to manipulate processes, however the most simple and often most effective is the **PID controller**. The controller attempts to correct the error between a measured process variable and desired setpoint by calculating the

difference and then performing a corrective action to adjust the process accordingly. A PID controller controls a process through three parameters: Proportional (P), Integral (I), and Derivative (D).

### Proportional (P) Control

One type of action used in PID controllers is the proportional control. Proportional control is a form of feedback control. It is the simplest form of continuous control that can be used in a closed-looped system. P-only control minimizes the fluctuation in the process variable, but it does not always bring the system to the desired set point. It provides a faster response than most other controllers, initially allowing the P-only controller to respond a few seconds faster. However, as the system becomes more complex (i.e. more complex algorithm) the response time difference could accumulate, allowing the P-controller to possibly respond even a few minutes faster. Although the P-only controller does offer the advantage of faster response time, it produces deviation from the set point. This deviation is known as the offset, and it is usually not desired in a process

P-control linearly correlates the controller output (actuating signal) to the error (difference between measured signal and set point). This P-control behavior is mathematically illustrated in Equation

$$c(t) = Kc e(t) + b \quad (9.2.2)$$

where

- $c(t)$  = controller output
- $Kc$  = controller gain
- $e(t)$  = error
- $b$  = bias

### Proportional-Integral (PI) Control

One combination is the **PI-control**, which lacks the D-control of the PID system. PI control is a form of feedback control. It provides a faster response time than I-only control due to the addition of the proportional action. PI control stops the system from fluctuating, and it is also able to return the system to its set point. Although the response time for PI-control is faster than I-only control, it is still up to 50% slower than P-only control. Therefore, in order to increase response time, PI control is often combined with D-only control.

PI-control correlates the controller output to the error and the integral of the error. This PI-control behavior is mathematically illustrated in Equation

$$c(t) = Kc(e(t) + 1/Ti \int e(t) dt) + C \quad (9.2.5)$$

where

- $c(t)$  is the controller output,
- $Kc$  is the controller gain,
- $Ti$  is the integral time,
- $e(t)$  is the error, and
- $C$  is the initial value of controller

In this equation, the integral time is the time required for the I-only portion of the controller to match the control provided by the P-only part of the controller.

The equation indicates that the PI-controller operates like a simplified PID-controller with a zero derivative term. Alternatively, the PI-controller can also be seen as a combination of the P-only and I-only control equations. The

bias term in the P-only control is equal to the integral action of the I-only control. The P-only control is only in action when the system is not at the set point. When the system is at the set point, the error is equal to zero, and the first term drops out of the equation. The system is then being controlled only by the I-only portion of the controller. Should the system deviate from the set point again, P-only control will be enacted. A graphical representation of the PI-controller output for a step increase in input at time  $t_0$  is shown below in Figure 5. As expected, this graph resembles the qualitative combination of the P-only and I-only graphs.

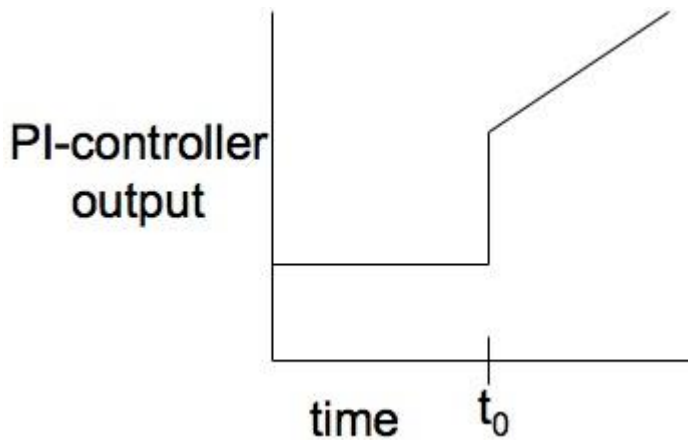

Figure . PI-controller output for step input.

### Proportional-Derivative (PD) Control

Another combination of controls is the PD-control, which lacks the I-control of the PID system. PD-control is combination of feedforward and feedback control, because it operates on both the current process conditions and predicted process conditions. In PD-control, the control output is a linear combination of the error signal and its derivative. PD-control contains the proportional control's damping of the fluctuation and the derivative control's prediction of process error.

As mentioned, PD-control correlates the controller output to the error and the derivative of the error. This PD-control behavior is mathematically illustrated in Equation .

$$c(t) = K_c(e(t) + T_d \frac{de(t)}{dt}) + C \quad (9.2.6)$$

where

- $c(t)$  = controller output
- $K_c$  = proportional gain
- $e$  = error
- $C$  = initial value of controller

The equation indicates that the PD-controller operates like a simplified PID-controller with a zero integral term. Alternatively, the PD-controller can also be seen as a combination of the P-only and D-only control equations. In

this control, the purpose of the D-only control is to predict the error in order to increase stability of the closed loop system. P-D control is not commonly used because of the lack of the integral term. Without the integral term, the error in steady state operation is not minimized. P-D control is usually used in batch pH control loops, where error in steady state operation does not need to be minimized. In this application, the error is related to the actuating signal both through the proportional and derivative term. A graphical representation of the PD-controller output for a step increase in input at time  $t_0$  is shown below in Figure 6. Again, this graph is a combination of the P-only and D-only graphs, as expected.

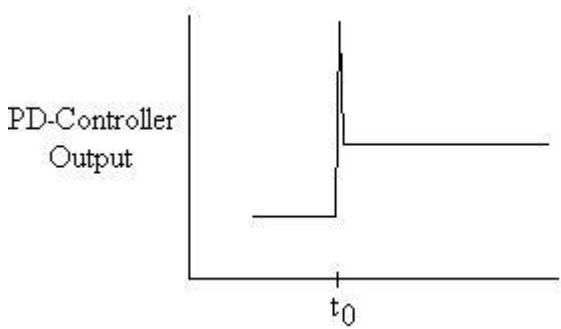

Figure . PD-controller output for step input.

### Proportional-Integral-Derivative (PID) Control

Proportional-integral-derivative control is a combination of all three types of control methods. PID-control is most commonly used because it combines the advantages of each type of control. This includes a quicker response time because of the P-only control, along with the decreased/zero offset from the combined derivative and integral controllers. This offset was removed by additionally using the I-control. The addition of D-control greatly increases the controller's response when used in combination because it predicts disturbances to the system by measuring the change in error. On the contrary, as mentioned previously, when used individually, it has a slower response time compared to the quicker P-only control. However, although the PID controller seems to be the most adequate controller, it is also the most expensive controller. Therefore, it is not used unless the process requires the accuracy and stability provided by the PID controller.

PID-control correlates the controller output to the error, integral of the error, and derivative of the error. This PID-control behavior is mathematically illustrated in Equation 6 (Scrccek, *et. al*).

$$c(t) = K_c(e(t) + 1/T_i \int e(t) dt + T_d \frac{de(t)}{dt}) + C \quad (9.2.7)$$

where

- $c(t)$  = controller output
- $K_c$  = controller gain
- $e(t)$  = error
- $T_i$  = integral time
- $T_d$  = derivative time constant
- $C$  = initial value of controller

As shown in the above equation, PID control is the combination of all three types of control. In this equation, the gain is multiplied with the integral and derivative terms, along with the proportional term, because in PID combination control, the gain affects the I and D actions as well. Because of the use of derivative control, PID control cannot be used in processes where there is a lot of noise, since the noise would interfere with the predictive, feedforward aspect. However, PID control is used when the process requires no offset and a fast response time. A graphical representation of the PID-controller output for a step increase in input at time  $t_0$  is shown below in Figure. This graph resembles the qualitative combination of the P-only, I-only, and D-only graphs.

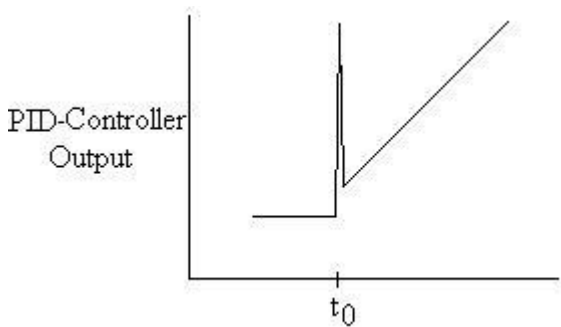

Figure PID-controller output for step input.

### Short Questions

1. **What is an order of a system?**

The order of a system is the order of the differential equation governing the system. The order of the system can be obtained from the transfer function of the given system.

2. **What is step signal?**

The step signal is a signal whose value changes from zero to A at  $t=0$  and remains constant at A for  $t>0$ .

3. **What is ramp signal?**

The ramp signal is a signal whose value increases linearly with time from an initial value of zero at  $t=0$ . The ramp signal resembles a constant velocity.

4. **What is a parabolic signal?**

The parabolic signal is a signal whose value varies as a square of time from an initial value of zero at  $t=0$ . This parabolic signal represents constant acceleration input to the signal.

**5. What is transient response?**

The transient response is the response of the system when the system changes from one state to another.

**6. What is steady state response?**

The steady state response is the response of the system when it approaches infinity.

**7. Define Damping ratio.**

Damping ratio is defined as the ratio of actual damping to critical Damping.

**8. List the time domain specifications.**

The time domain specifications are

i. Delay time

ii. Rise time

iii. Peak time

iv. Peak overshoot

**9. What is damped frequency of oscillation?**

In under damped system the response is damped oscillatory. The frequency of damped oscillation is given by  $\omega_d = \omega_n \sqrt{1 - \zeta^2}$

**10. What will be the nature of response of second order system with different types of damping?**

For undamped system the response is oscillatory.

For under damped system the response is damped oscillatory.

For critically damped system the response is exponentially rising.

For over damped system the response is exponentially rising but the rise time will be very large.

**11. Define Delay time.**

The time taken for response to reach 50% of final value for the very first time is delay time.

**12. Define Rise time.**

The time taken for response to raise from 0% to 100% for the very first time is rise time.

**13. Define peak time**

The time taken for the response to reach the peak value for the first time is peak time.

**14. Define peak overshoot.**

Peak overshoot is defined as the ratio of maximum peak value measured from the Maximum value to final value

**15. Define Settling time.**

Settling time is defined as the time taken by the response to reach and stay within specified error

**16. What is the need for a controller?**

The controller is provided to modify the error signal for better control action.

**17. What are the different types of controllers?**

The different types of the controller are

Proportional controller

PI controller

PD controller

PID controller

**18. What is proportional controller?**

It is device that produces a control signal which is proportional to the input error signal.

**19. What is PI controller?**

It is device that produces a control signal consisting of two terms –one proportional to error signal and the other proportional to the integral of error signal.

**20. What is PD controller?**

PD controller is a proportional plus derivative controller which produces an output signal consisting of two terms -one proportional to error signal and other proportional to the derivative of the signal.

**21. What is the significance of integral controller and derivative controller in a PID controller?**

The proportional controller stabilizes the gain but produces a steady state error. The integral control reduces or eliminates the steady state error.

**22. Define Steady state error.**

The steady state error is the value of error signal  $e(t)$  when  $t$  tends to infinity.

**23. What is the drawback of static coefficients?**

The main drawback of static coefficient is that it does not show the variation of error with time and input should be standard input.

**24. What are the three constants associated with a steady state error?**

The three steady state errors constant are

Positional error constant  $K_p$

Velocity error constant  $K_v$

Acceleration error constant  $K_a$

**25. What are the main advantages of generalized error co-efficients?**

i) Steady state is function of time.

ii) Steady state can be determined from any type of input.

**26. What are the effects of adding a zero to a system?**

Adding a zero to a system results in pronounced early peak to system response thereby the peak overshoot increases appreciably.

**27. Why derivative controller is not used in control system?**

The derivative controller produces a control action based on rate of change of error signal and it does not produce corrective measures for any constant error. Hence derivative controller is not used in control system

**28. What is the effect of PI controller on the system performance?**

The PI controller increases the order of the system by one, which results in reducing the steady state error .But the system becomes less stable than the original system.

**29. What is the effect of PD controller on system performance?**

The effect of PD controller is to increase the damping ratio of the system and so the peak overshoot is reduced.

**30. What is the disadvantage in proportional controller?**

The disadvantage in proportional controller is that it produces a constant steady state error.

**Long Questions**

1. Derive time response of first order system with unit step response?
2. explain different types of controller?
3. Derive expression for rise time ,peak time, peak overshoot,?

## Chapter-6

### Analysis of Stability By root Locus Technique

#### 6.1.Root Locus concept

# Root Locus Plots in Control Systems

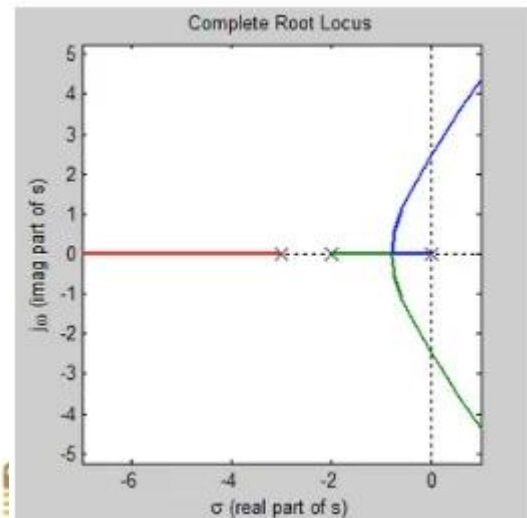
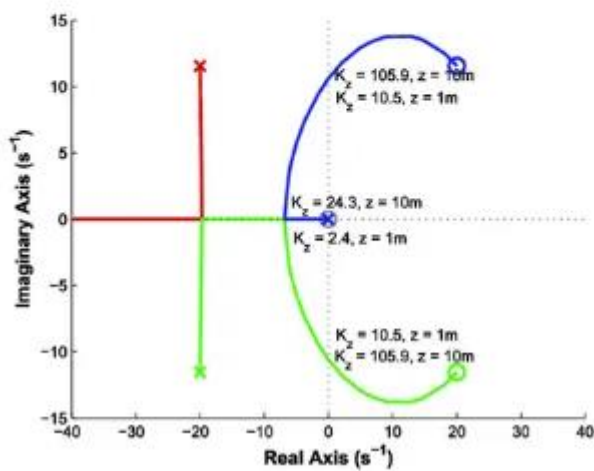

The **root locus technique in control system** was first introduced in the year 1948 by Evans. Any physical system is represented by a transfer function in the form of

$$G(s) = k \times \frac{\text{numerator of } s}{\text{denominator of } s}$$

We can find poles and zeros from  $G(s)$ . The location of poles and zeros are crucial keeping view stability, relative stability, transient response and error analysis. When the system is put to service stray **inductance** and **capacitance** get into the system, thus changes the location of poles and zeros. In **root locus technique in control system** we will evaluate the position of the roots, their locus of movement and associated information. These information will be used to comment upon the system performance.

Now before I introduce what is a root locus technique, it is very essential here to discuss a few of the advantages of this technique over other stability criteria. Some of the advantages of root locus technique are written below.

#### Advantages of Root Locus Technique

1. Root locus technique in control system is easy to implement as compared to other methods.
2. With the help of root locus we can easily predict the performance of the whole system.
3. Root locus provides the better way to indicate the parameters.

Now there are various terms related to root locus technique that we will use frequently in this article.

1. Characteristic Equation Related to Root Locus Technique :  $1 + G(s)H(s) = 0$  is known as characteristic equation. Now on differentiating the characteristic equation and on equating  $dk/ds$  equals to zero, we can get break away points.

2. Break away Points : Suppose two root loci which start from pole and moves in opposite direction collide with each other such that after collision they start moving in different directions in the symmetrical way. Or the breakaway points at which multiple roots of the characteristic equation  $1 + G(s)H(s) = 0$  occur. The value of K is maximum at the points where the branches of root loci break away. Break away points may be real, imaginary or complex.
3. Break in Point : Condition of break in to be there on the plot is written below : Root locus must be present between two adjacent zeros on the real axis.
4. Centre of Gravity : It is also known centroid and is defined as the point on the plot from where all the asymptotes start. Mathematically, it is calculated by the difference of summation of poles and zeros in the transfer function when divided by the difference of total number of poles and total number of zeros. Centre of gravity is always real and it is denoted by  $\sigma_A$ .

$$\sigma_A = \frac{(\text{Sum of real parts of poles}) - (\text{Sum of real parts of zeros})}{N - M}$$

Where, N is number of poles and M is number of zeros.

5. Asymptotes of Root Loci : Asymptote originates from the center of gravity or centroid and goes to infinity at definite some angle. Asymptotes provide direction to the root locus when they depart break away points.
6. Angle of Asymptotes : Asymptotes makes some angle with the real axis and this angle can be calculated from the given formula,

$$\text{Angle of asymptotes} = \frac{(2p + 1) \times 180}{N - M}$$

Where,  $p = 0, 1, 2, \dots, (N-M-1)$

N is the total number of poles

M is the total number of zeros.

7. Angle of Arrival or Departure : We calculate angle of departure when there exists complex poles in the system. Angle of departure can be calculated as  $180 - \{(\text{sum of angles to a complex pole from the other poles}) - (\text{sum of angle to a complex pole from the zeros})\}$ .
8. Intersection of Root Locus with the Imaginary Axis : In order to find out the point of intersection root locus with imaginary axis, we have to use Routh Hurwitz criterion. First, we find the auxiliary equation then the corresponding value of K will give the value of the point of intersection.
9. Gain Margin : We define gain margin by which the design value of the gain factor can be multiplied before the system becomes unstable. Mathematically it is given by the formula

$$\text{Gain margin} = \frac{\text{Value of } K \text{ at the imaginary axes cross over}}{\text{Design value of } K}$$

10. Phase Margin : Phase margin can be calculated from the given formula:

$$\text{Phase margin} = 180 + \angle(G(j\omega)H(j\omega))$$

11. Symmetry of Root Locus : Root locus is symmetric about the x axis or the real axis.

How to determine the value of K at any point on the root loci? Now there are two ways of determining the value of K, each way is described below.

1. Magnitude Criteria : At any points on the root locus we can apply magnitude criteria as,

$$|G(s)H(s)| = 1$$

Using this formula we can calculate the value of K at any desired point.

2. Using Root Locus Plot : The value of K at any s on the root locus is given by

$$K = \frac{\text{product of all of the vector lengths drawn from the poles of } G(s)H(s) \text{ to } s}{\text{product of all of the vector lengths drawn from the zeros of } G(s)H(s) \text{ to } s}$$

## 6.2.Construction of Root Locus Plot

This is also known as root locus technique in control system and is used for determining the stability of the given system. Now in order to determine the stability of the system using the root locus technique we find the range of values of K for which the complete performance of the system will be satisfactory and the operation is stable. Now there are some results that one should remember in order to plot the root locus. These results are written below:

1. Region where root locus exists : After plotting all the poles and zeros on the plane, we can easily find out the region of existence of the root locus by using one simple rule which is written below, Only that segment will be considered in making root locus if the total number of poles and zeros at the right hand side of the segment is odd.
2. How to calculate the number of separate root loci ? : A number of separate root loci are equal to the total number of roots if number of roots are greater than the number of poles otherwise number of separate root loci is equal to the total number of poles if number of roots are greater than the number of zeros.

## 6.3.Rules to Plot Root Locus

Keeping all these points in mind we are able to draw the **root locus plot** for any kind of system. Now let us discuss the procedure of making a root locus.

1. Find out all the roots and poles from the open loop transfer function and then plot them on the complex plane.
2. All the root loci starts from the poles where k = 0 and terminates at the zeros where K tends to infinity. The number of branches terminating at infinity equals to the difference between the number of poles & number of zeros of G(s)H(s).
3. Find the region of existence of the root loci from the method described above after finding the values of M and N.
4. Calculate break away points and break in points if any.
5. Plot the asymptotes and centroid point on the complex plane for the root loci by calculating the slope of the asymptotes.
6. Now calculate angle of departure and the intersection of root loci with imaginary axis.
7. Now determine the value of K by using any one method that I have described above.  
By following above procedure you can easily draw the **root locus plot** for any open loop transfer function.
8. Calculate the gain margin.
9. Calculate the phase margin.
10. You can easily comment on the stability of the system by using Routh Array.

## Effects of Adding Open Loop Poles and Zeros on Root Locus

The root locus can be shifted in 's' plane by adding the open loop poles and the open loop zeros.

- If we include a pole in the open loop transfer function, then some of root locus branches will move towards right half of 's' plane. Because of this, the damping ratio  $\delta$  decreases. Which implies, damped frequency  $\omega_d$  increases and the time domain specifications like delay time  $t_{dd}$ , rise time  $t_{rr}$  and peak time  $t_{pt}$  decrease. But, it effects the system stability.
- If we include a zero in the open loop transfer function, then some of root locus branches will move towards left half of 's' plane. So, it will increase the control system stability. In this case, the damping ratio  $\delta$  increases. Which implies, damped frequency  $\omega_d$  decreases and the time domain specifications like delay time  $t_{dd}$ , rise time  $t_{rr}$  and peak time  $t_{pt}$  increase.

So, based on the requirement, we can include (add) the open loop poles or zeros to the transfer function.

### Short questions

1. Consider the loop transfer function  $K(s+6)/(s+3)(s+5)$  find out- In the root locus diagram the centroid will be located at \_\_\_\_\_?

Ans- Centroid = Sum of real part of open loop pole - sum of real part of open loop zeros / P-Z.

2. What is the number of the root locus segments which do not terminate on zeroes?

Ans- The number of the root locus segments which do not lie on the root locus is the difference between the number of the poles and zeroes.

3. If the gain of the system is reduced to a zero value, the roots of the system in the s-plane,

Ans- The roots of the system in s plane coincides with the poles if the gain of the system is reduced to a value zero.

4. When the number of poles is equal to the number of zeroes, how many branches of root locus tends towards infinity?

Ans: Branches of the root locus is equal to the number of poles or zeroes which ever is greater and tends toward infinity when poles or zeroes are unequal.

Long question:

1. Sketch the root loci for the system shown in Figure ). (The gain  $K$  is assumed to be positive.) Observe that for small or large values of  $K$  the system is overdamped and for medium values of  $K$  it is underdamped.

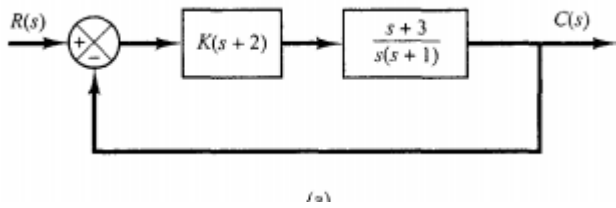

2. Sketch the root loci of the control system shown in Figure

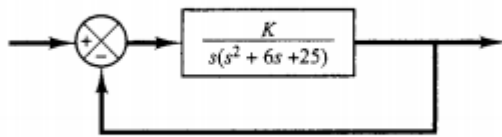

## Chapter-7

### Frequency response Analysis

#### 7.1. Corelation between time response and frequency response

As has been stated, the use of frequency response for the design of control systems requires a Correlation Between Frequency and Transient Response. Time response specifications are available for the performance of a system. These must be translated to frequency response. There must be frequency domain specifications also, corresponding to the time domain specifications, such as overshoot, settling time, etc. However, it is easy to have a direct Correlation Between Frequency and Transient Response of a second order system. A typical [magnitude plot](#) of a second order system is shown in Fig. 6.17.

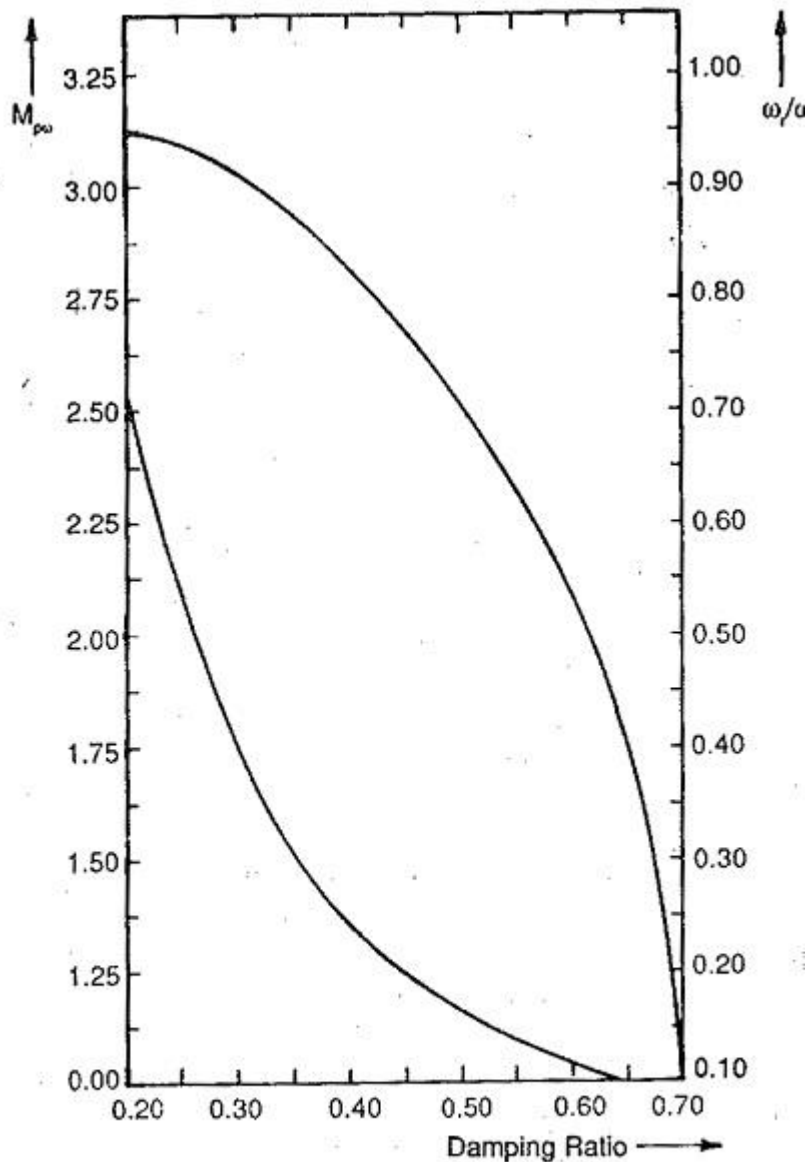

**Fig. 6.18** Peak of frequency response and resonating frequency of second order system as a function of damping ratio

The resonant peak (maximum amplitude)  $M_{p\omega}$  of the magnitude plot depends upon the damping ratio of the system. The resonant frequency also depends upon the damping ratio. These relations are given by Eqs 6.59 and 6.60 and represented graphically in Fig. 6.18. The resonant frequency  $\omega_r$  and band width of the frequency response relate to the fastness of response. Smaller the values of bandwidth and resonant frequency smaller is the rise time of the transient response and faster is the response. The overshoot of the time response can be related to the resonant peak of the frequency response. This resonant peak also indicates the [relative stability](#) of the systems. The bandwidth is related to the natural frequency  $\omega_n$  of the system. For a given  $\xi$  greater the value  $\omega_n$  faster is the response. The value of  $\xi$  must be chosen to compromise between  $M_{p\omega}$  and  $\omega_r$ .

The frequency domain specifications are therefore

**1. The peak amplitude and the frequency at which this occurs. The peak amplitude must be normally less than 1.5. The acceptable range of peak amplitude corresponds to damping rates of 0.4 to 0.7.**

**2. Relatively large resonant frequency and hence large bandwidth of the frequency response. The system will have relatively small time constants. The system becomes faster.**

**3. The closeness of the polar plot of frequency response to (-1, 0) point indicates the peak overshoot of the time response. This also gives the relative**

**4. The steady-state error can be related to frequency response also. The gain and number of integrations involved in the open loop system indicate the influence of steady-state error.**

The Correlation Between Frequency and Transient Response of higher order systems is not so simple and straightforward as it is for second order systems. The mathematical treatment of higher order systems for such a correlation is rather involved and laborious. However, a higher order system can be represented by a second order system if it has a pair of dominant complex conjugate poles. The frequency and time responses of this system is influenced by this pair of dominant poles. In such a case the Correlation Between Frequency and Transient Response for a second order system can be very easily extended for higher order systems.

For higher order systems having a dominant pair of complex conjugate poles, the following correlation exists between the transient and frequency responses:

**1. The peak magnitude of frequency response indicates the relative stability. A system having a peak amplitude in the range of 1 to 1.4 would have a time response with an effective damping ratio in the range of 0.4 to 0.7.**

**2. If the peak amplitude of the frequency response is greater than 1.5 the time response is oscillatory, having a large overshoot.**

**3. The resonant frequency, i.e. the frequency corresponding to peak amplitude, is a measure of the fastness of response. Larger the value of resonant frequency, faster is the response, i.e. the smaller is the rise time.**

**4. The system is highly damped if the resonant frequency and damped natural frequency are close to each other.**

**5. Larger values of  $\omega_r$  characterize larger bandwidth. However, in view of the noise the system should not have large bandwidth. Larger the bandwidth costlier is the system. A compromise is required.**

**6. Cut off frequency (frequency at which the amplitude is 3 db below the zero frequency value) characterises the filtering characteristics of high frequency**

**7. The slope of the log-magnitude curves known as cut off rate gives the ability of the control system to distinguish between noise and signal.**

Using the above correlation, the time domain specifications can be translated to frequency domain specifications. The design of the control system is carried out in the frequency domain to meet the required specifications.

## 7.2.Polar Plot

**Definition:** The plot that represents the [transfer function](#) of the system  $G(j\omega)$  on a complex plane, constructed in polar coordinates is known as Polar Plot.

The polar plot representation shows the plot of magnitude versus phase angle on polar coordinates with variation in  $\omega$  from 0 to  $\infty$ . It is used for stability analysis.

### Construction of Polar Plot

It is known to us that plotting frequency response signifies sketching the variations in the magnitude and phase angle with respect to the input frequency. These plots are known as magnitude plot (gain plot) and phase plot respectively.

In the Bode plot, the frequency response is sketched using a logarithmic scale.

So, in a polar plot, a sketch between the magnitude and phase angle of the transfer function  $G(j\omega)$  is formed for different values of  $\omega$ .

Suppose  $M$  represents the magnitude and  $\phi$  denotes the phase angle, then for the

$$M = | G(j\omega) H(j\omega) |$$

transfer function of a system it is given as:  $\phi = \angle G(j\omega) H(j\omega)$

So, with the variation in  $\omega$  from 0 to  $\infty$ , the values of  $M$  and  $\phi$  can be determined.

As we have already discussed in the beginning that polar plot is magnitude versus phase angle graph plotted for various values of  $\omega$ .

So, to construct a polar plot, the different values of magnitude and phase angle is tabulated and further, the sketch is formed. The table is given below:

Frequency	Magnitude	Phase Angle
0	$M_0$	$\phi_0$
$\omega_1$	$M_1$	$\phi_1$
$\omega_2$	$M_2$	$\phi_2$
$\infty$	$M_\infty$	$\phi_\infty$

Basically, here each point on the polar plot is significantly plotted for each specific value of magnitude and phase angle for particular frequency  $\omega$ .

Like from the above table, for  $\omega = \omega_1$ ,  $M = M_1$  and  $\phi = \phi_1$  a point in the polar coordinate system is decided that represents  $M_1 \angle \phi_1$ , hence, the point on the plot corresponds to the tip of the phasor of magnitude  $M_1$  plotted at an angle  $\phi_1$ .

So, by using the tabulated data, the polar plot can be formed. Thus, in this way, the magnitude vs phase angle plot is can be constructed for various values of frequency.

It is to be noted here that conversion of magnitude into dB or logarithm values is not necessary. Also, the anticlockwise direction represents positive phase angles, while the clockwise direction shows the negative phase angles.

The figure below represents the polar plot for  $\omega$  between  $0$  to  $\infty$ :

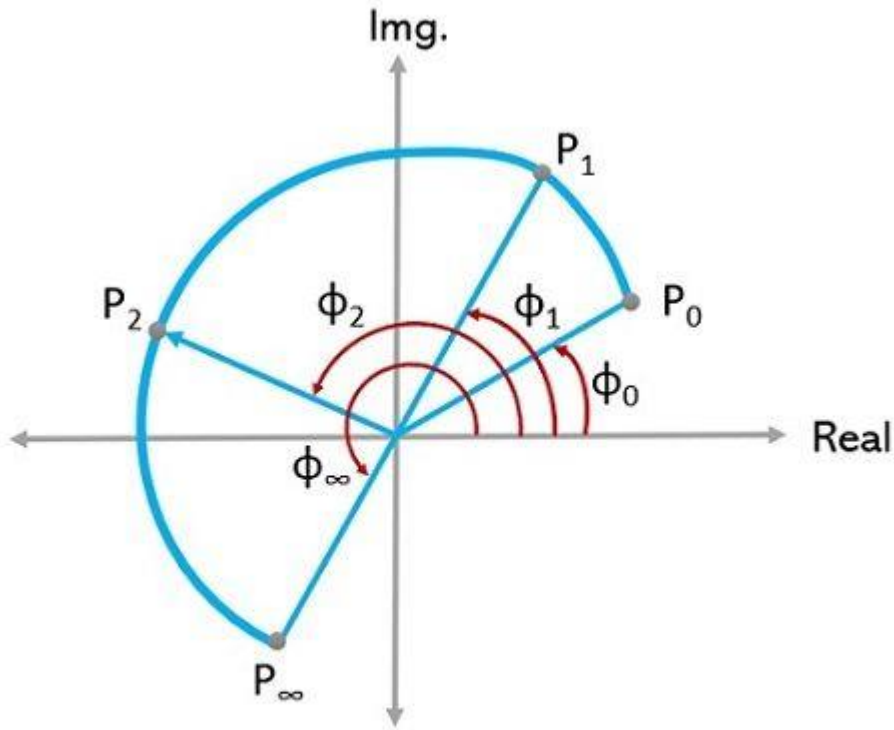

**Polar Plot**

Electronics Coach

Thus, from the above discussion, we can conclude that polar plot is started from a point specifying magnitude and angle for  $\omega = 0$  and is terminated at a point specifying magnitude and angle for  $\omega = \infty$ .

- Another method is used to roughly sketch a polar plot in which magnitude and angles for the various values of  $\omega$  are not calculated.

Basically, in a polar coordinate system, suppose we have two points  $n_1 \angle \phi_1$  and  $n_2 \angle \phi_2$  as

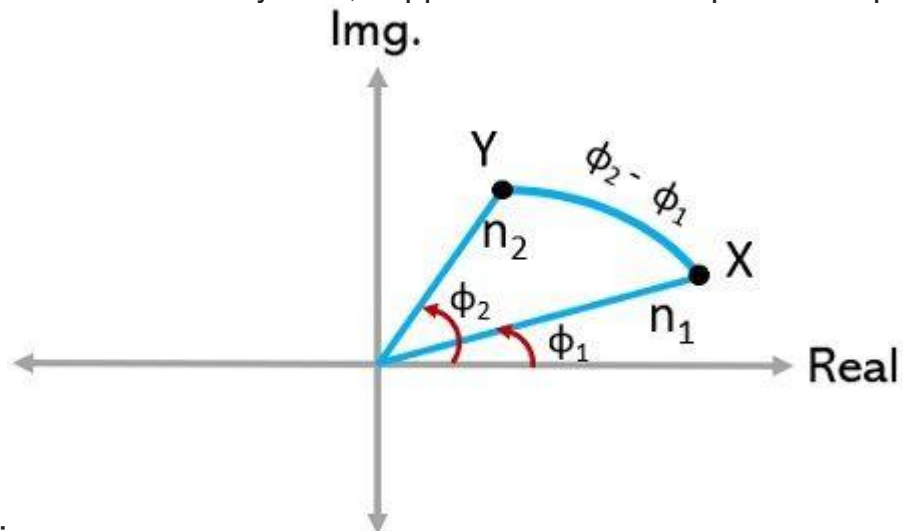

indicated below:

Here, it is clear from the above figure that movement of point X from Y, causes an angle rotation,  $\phi_2 - \phi_1$ . And if the difference is negative, the rotation will be in the clockwise direction. While, if the difference is positive, the rotation will be in the anti-clockwise direction.

In a similar way, the variation in  $\omega$  from 0 to  $\infty$ , two points can be considered. One at  $\omega = 0$ , with magnitude  $M_0$  and angle  $\phi_0$  while the other at  $\omega = \infty$  with magnitude  $M_\infty$  and angle  $\phi_\infty$ . Then there will be a rotation from  $\phi_\infty$  to  $\phi_0$ .

More simply,

$\omega = 0$  gives  $M_0 \angle \phi_0$  is the starting point,

$\omega = \infty$  gives  $M_\infty \angle \phi_\infty$  is the terminating point and

$\phi_\infty - \phi_0$  corresponds to the rotation

Hence, in this way, the polar plot can be constructed.

### Example of Polar Plot

Till now, we have discussed what basically a polar plot is and how it is constructed let us now consider an example to understand the construction of polar plot in a better way.

$$G(s) = \frac{1}{1+s}$$

Suppose we have a Type 0 system whose transfer function is given as:

We have to sketch the polar plot for it.

The first step is to convert the given transfer function into the frequency domain. Thus, it

$$G(j\omega) = \frac{1}{1+j\omega}$$

$$G(j\omega) = \frac{1+j0}{1+j\omega}$$

will be written as:

Now, further calculating the magnitude,  $|G(j\omega) H(j\omega)| = M = \frac{1}{\sqrt{1+\omega^2}}$

$$\angle G(j\omega) H(j\omega) = \phi = \frac{\tan^{-1}\left(\frac{0}{1}\right)}{\tan^{-1}\left(\frac{\omega}{1}\right)}$$

$$\angle G(j\omega) H(j\omega) = \phi = \frac{0^\circ}{(\tan^{-1}\omega)}$$

Also, the phase angle condition,  $\angle G(j\omega) H(j\omega) = \phi = -\tan^{-1}(\omega)$

Now, we have to calculate magnitude and angle by substituting different values of  $\omega$  between 0 and  $\infty$ .

Thus, the tabular representation will be:

Frequency	Magnitude	Phase Angle
0	1	0°
1	$1/\sqrt{2}$	-45°
10	$1/\sqrt{101}$	-84.2°
$\infty$	0	-90°

Hence, the tabulated data shows that the starting point is 1  $\angle 0^\circ$  and terminating point is 0  $\angle -90^\circ$ . Thus, the plot will terminate at the origin, tangential to the axis of angle  $-90^\circ$ .

Thus, the plot is represented as:

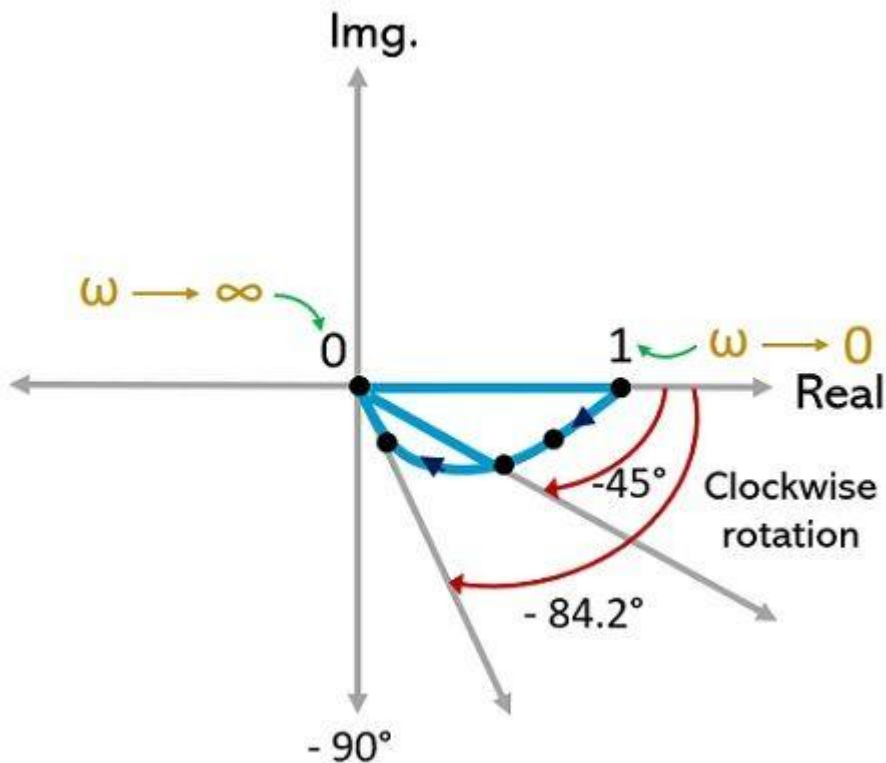

Now, let us apply the alternative method to sketch the polar plot.

As we have discussed earlier that in this method only the starting and terminating points are of major significance. Thus, frequency is needed for 0 and  $\infty$ .

From the above tabular representation, it is clear that,

For,  $\omega = 0$  magnitude and angle =  $1 \angle 0^\circ$

For,  $\omega = \infty$  magnitude and angle =  $0 \angle -90^\circ$

Therefore,

$$\varphi_\infty - \varphi_0 = -90^\circ - 0^\circ = -90^\circ$$

As the difference of the two is negative, thus, the rotation from starting to the terminating point will be in the clockwise direction.

Thus, the starting point,  $1 \angle 0^\circ$  is rotated  $90^\circ$  in the clockwise direction, in order to get terminated at  $0 \angle -90^\circ$ . Hence, the rough sketch of the polar plot is given below:

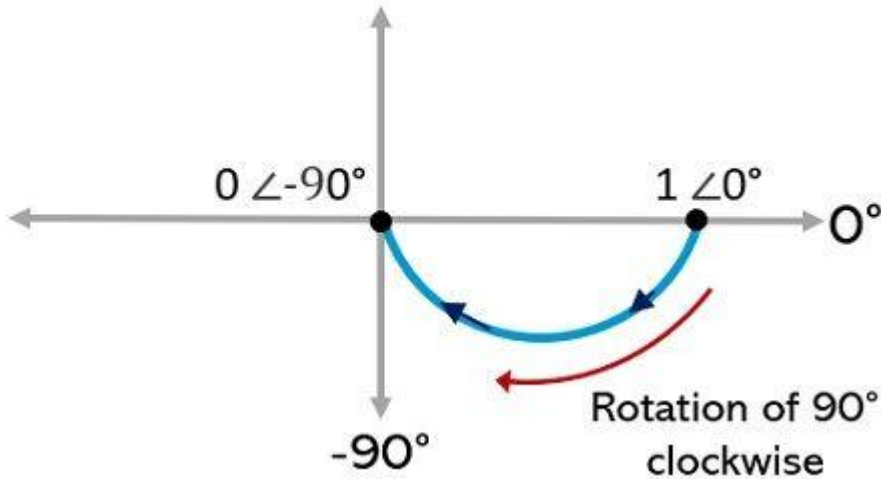

It is to be noted here that mostly this approximate method is used for sketching the polar plot.

### 7.3. Bode Plot

The Bode plot or the Bode diagram consists of two plots –

- Magnitude plot
- Phase plot

In both the plots, x-axis represents angular frequency (logarithmic scale). Whereas, y-axis represents the magnitude (linear scale) of open loop transfer function in the magnitude plot and the phase angle (linear scale) of the open loop transfer function in the phase plot.

The **magnitude** of the open loop transfer function in dB is -

$$M = 20 \log |G(j\omega)H(j\omega)| \quad M = 20 \log_{10} |G(j\omega)H(j\omega)|$$

The **phase angle** of the open loop transfer function in degrees is -

$$\varphi = \angle G(j\omega)H(j\omega) \quad \varphi = \angle G(j\omega)H(j\omega)$$

**Note** – The base of logarithm is 10.

### Basic of Bode Plots

The following table shows the slope, magnitude and the phase angle values of the terms present in the open loop transfer function. This data is useful while drawing the Bode plots.

Type of term	$G(j\omega)H(j\omega)$	Slope(dB/dec)	Magnitude (dB)	Phase angle(degrees)
Constant	$K$	0	$20\log K$	0
Zero at origin	$j\omega$	20	$20\log\omega$	90
'n' zeros at origin	$(j\omega)^n$	20n	$20n\log\omega$	90n
Pole at	$1/j\omega$	-20	$-20\log\omega$	-90 or 270

origin				
'n' poles at origin	$1(j\omega)^n$	$-20n$	$-20n \log \omega$	$-90n$ or $270n$
Simpl e zero	$1+j\omega r$	$20$	$0$ for $\omega < 1/r$ $20 \log \omega$ for $\omega > 1/r$	$0$ for $\omega < 1/r$ $90$ for $\omega > 1/r$
Simpl e pole	$1+1+j\omega r$	$-20$	$0$ for $\omega < 1/r$ $-20 \log \omega$ for $\omega > 1/r$	$0$ for $\omega < 1/r$ $-90$ or $270$ for $\omega > 1/r$
Secon d order deriv ative term	$\omega^2(1-\omega^2\omega_n^2+2j\delta\omega\omega_n)$	$40$	$40 \log \omega_n$ for $\omega < \omega_n$ $20 \log(2\delta\omega_n)$ for $\omega = \omega_n$ $40 \log \omega$ for $\omega > \omega_n$	$0$ for $\omega < \omega_n$ $90$ for $\omega = \omega_n$ $180$ for $\omega > \omega_n$
Secon d order integr al term	$1/\omega^2(1-\omega^2\omega_n^2+2j\delta\omega\omega_n)$	$-40$	$-40 \log \omega_n$ for $\omega < \omega_n$ $-20 \log(2\delta\omega_n)$ for $\omega = \omega_n$ $-40 \log \omega$ for $\omega > \omega_n$	$-0$ for $\omega < \omega_n$ $-90$ for $\omega = \omega_n$ $-180$ for $\omega > \omega_n$

Consider the open loop transfer function  $G(s)H(s)=KG(s)H(s)=K$ .

Magnitude  $M=20 \log KM=20 \log K$  dB

Phase angle  $\varphi=0$  degrees

If  $K=1$ , then magnitude is 0 dB.

If  $K>1$ , then magnitude will be positive. If

$K<1$ , then magnitude will be negative.

The following figure shows the corresponding Bode plot.

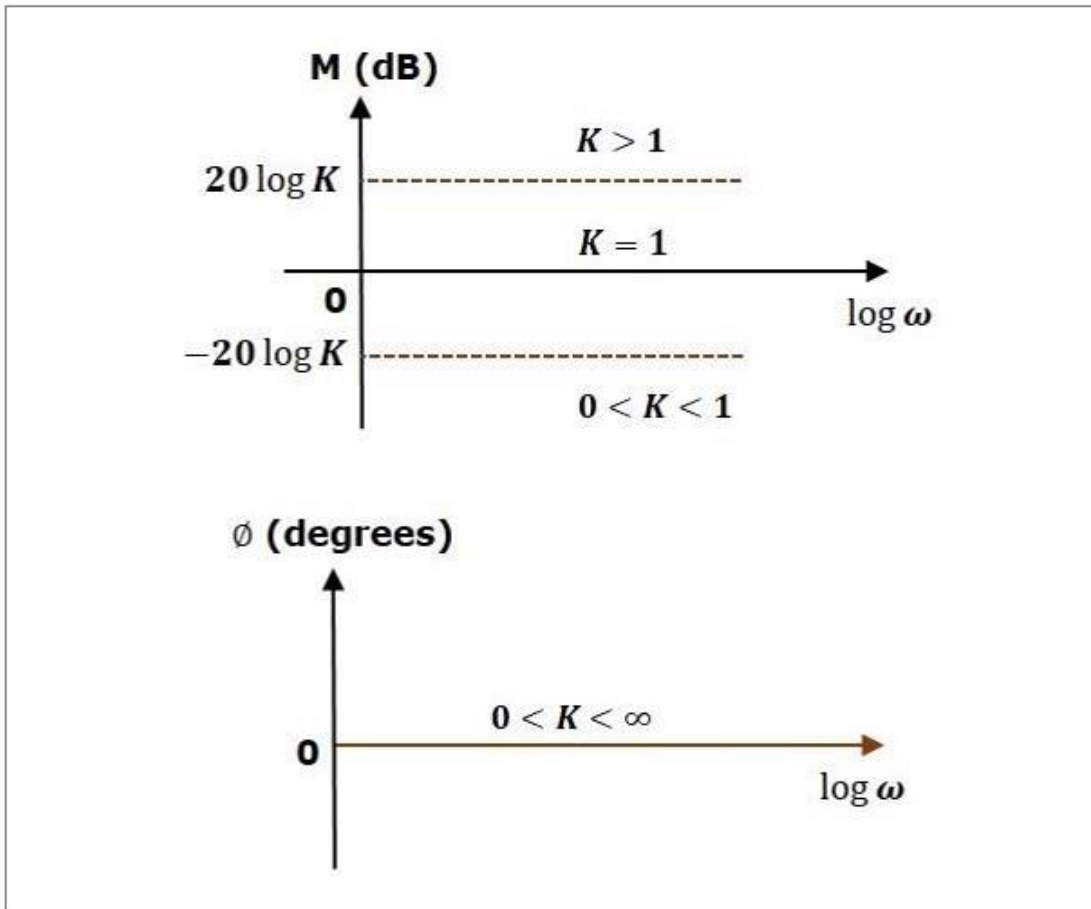

The magnitude plot is a horizontal line, which is independent of frequency. The 0 dB line itself is the magnitude plot when the value of K is one. For the positive values of K, the horizontal line will shift  $20\log K$  dB above the 0 dB line. For the negative values of K, the horizontal line will shift  $20\log K$  dB below the 0 dB line. The Zero degrees line itself is the phase plot for all the positive values of K.

Consider the open loop transfer function  $G(s)H(s) = \frac{K}{s}$ .

Magnitude  $M = 20\log \frac{K}{\omega}$  dB

Phase angle  $\phi = -90^\circ$

At  $\omega = 0.1$  rad/sec, the magnitude is -20 dB. At  $\omega = 1$  rad/sec, the magnitude is 0 dB.

At  $\omega = 10$  rad/sec, the magnitude is 20 dB.

The following figure shows the corresponding Bode plot.

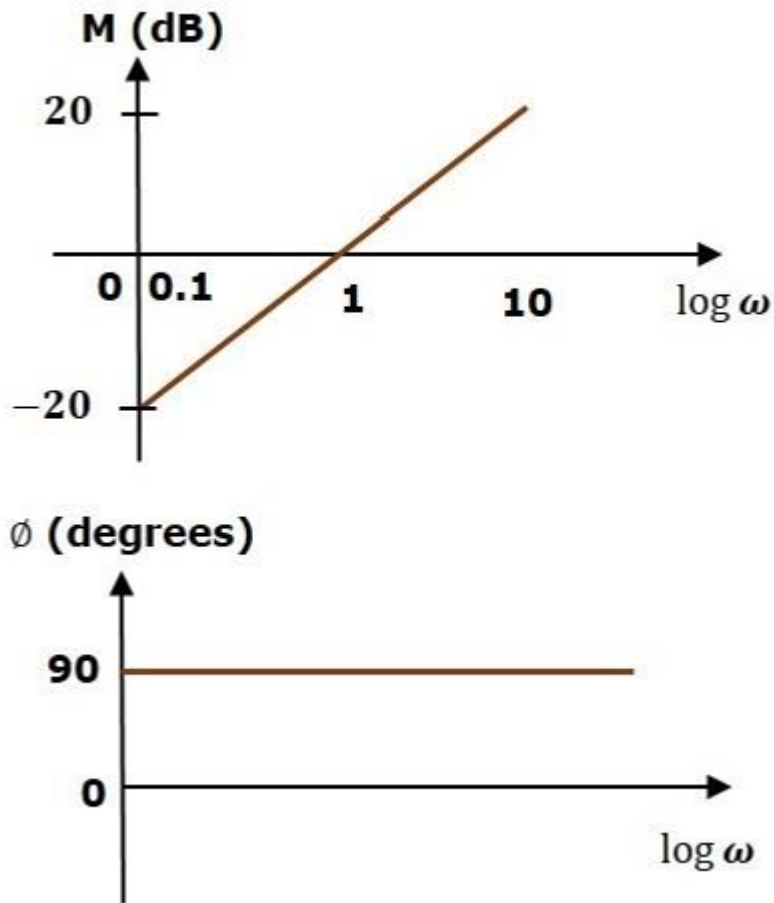

The magnitude plot is a line, which is having a slope of 20 dB/dec. This line started at  $\omega=0.1$  rad/sec having a magnitude of -20 dB and it continues on the same slope. It is touching 0 dB line at  $\omega=1$  rad/sec. In this case, the phase plot is  $90^\circ$  line.

Consider the open loop transfer function  $G(s)H(s)=1+s\tau$ .

Magnitude  $M=20\log\sqrt{1+\omega^2\tau^2}$  dB

Phase angle  $\phi=\tan^{-1}\omega\tau$  degrees

For  $\omega < 1/\tau$ , the magnitude is 0 dB and phase angle is 0 degrees.

For  $\omega > 1/\tau$ , the magnitude is  $20\log\omega\tau$  dB and phase angle is  $90^\circ$ . The following figure shows the corresponding Bode plot.

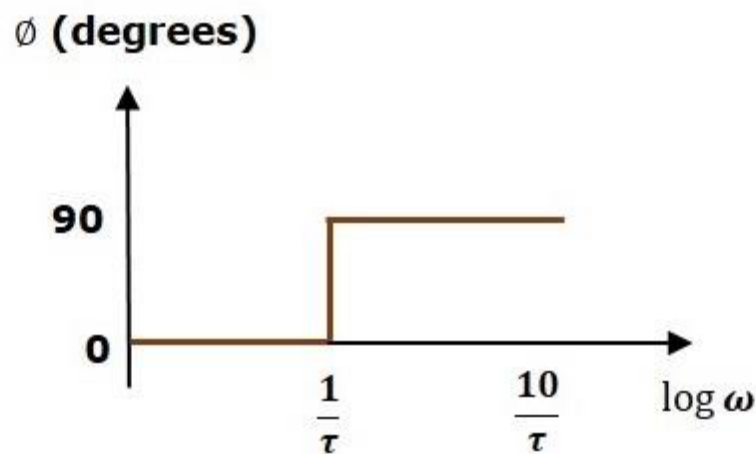
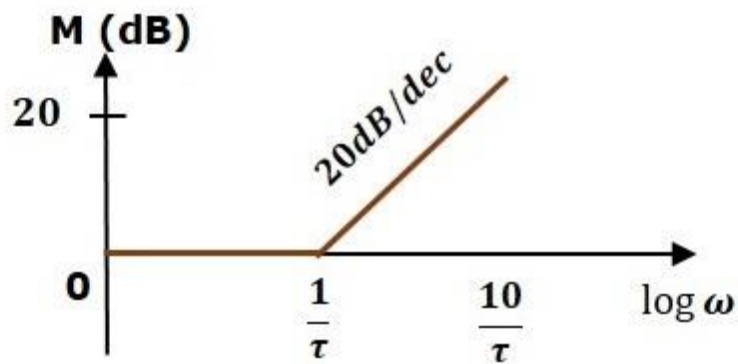

The magnitude plot is having magnitude of 0 dB upto  $\omega = \frac{1}{\tau}$  rad/sec. From  $\omega = \frac{1}{\tau}$  rad/sec, it is having a slope of 20 dB/dec. In this case, the phase plot is having phase angle of 0 degrees up to  $\omega = \frac{1}{\tau}$  rad/sec and from here, it is having phase angle of  $90^\circ$ . This Bode plot is called the **asymptotic Bode plot**.

As the magnitude and the phase plots are represented with straight lines, the Exact Bode plots resemble the asymptotic Bode plots. The only difference is that the Exact Bode plots will have simple curves instead of straight lines.

Similarly, you can draw the Bode plots for other terms of the open loop transfer function which are given in the table.

## Rules for Construction of Bode Plots

Follow these rules while constructing a Bode plot.

- Represent the open loop transfer function in the standard time constant form.
- Substitute,  $s = j\omega$  in the above equation.
- Find the corner frequencies and arrange them in ascending order.
- Consider the starting frequency of the Bode plot as  $1/10^{\text{th}}$  of the minimum corner frequency or 0.1 rad/sec whichever is smaller value and draw the Bode plot upto 10 times maximum corner frequency.

- Draw the magnitude plots for each term and combine these plots properly.
- Draw the phase plots for each term and combine these plots properly.

**Note** – The corner frequency is the frequency at which there is a change in the slope of the magnitude plot.

## Example

Consider the open loop transfer function of a closed loop control system

$$G(s)H(s) = 10s(s+2)(s+5) \quad G(s)H(s) = 10s(s+2)(s+5)$$

Let us convert this open loop transfer function into standard time constant form.

$$G(s)H(s) = 10s^2(s+2)(s+5) \quad G(s)H(s) = 10s^2(s+2)(s+5)$$

$$\Rightarrow G(s)H(s) = s(1+s/2)(1+s/5) \Rightarrow G(s)H(s) = s(1+s/2)(1+s/5)$$

So, we can draw the Bode plot in semi log sheet using the rules mentioned earlier

## 7.4. Minimum phase system.

- A transfer function  $G(s)$  is minimum phase if both  $G(s)$  and  $1/G(s)$  are causal and stable.
- Roughly speaking it means that the system does not have zeros or poles on the right-half plane. Moreover, it does not have delay.
- Bode discovered that the phase can be uniquely derived from the slope of the magnitude for minimum-phase system. **Bode's Relation**

Basic Factor	Mag Slope(Low Freq)	Phase(Low Freq)	Mag Slope(High Freq)	Phase (High Freq)
K	0	0	0	0
$s^N$	20N	90N	20N	90N
$1/(\tau s + 1)$	0	0	-20	-90
$1/((s/\omega_n)^2 + 2\zeta(s/\omega_n) + 1)$	0	0	-40	-180

### 1.6 Non Minimum Phase System: Unstable Zeros

## 7.5. Gain Margin and phase margin

Gain margin GM is equal to negative of the magnitude in dB at phase cross over frequency.

$$GM = 20 \log(1/M_{pc}) = 20 \log M_{pc} \quad GM = 20 \log \frac{1}{M_{pc}} = 20 \log M_{pc}$$

Where,  $M_{pc}$  is the magnitude at phase cross over frequency. The unit of gain margin (GM) is **dB**.

## Phase Margin

The formula for phase margin  $PM$  is

$$PM = 180^\circ + \varphi_{gc}$$

Where,  $\varphi_{gc}$  is the phase angle at gain cross over frequency. The unit of phase margin is **degrees**.

The stability of the control system based on the relation between gain margin and phase margin is listed below.

- If both the gain margin  $GM$  and the phase margin  $PM$  are positive, then the control system is **stable**.
- If both the gain margin  $GM$  and the phase margin  $PM$  are equal to zero, then the control system is **marginally stable**.
- If the gain margin  $GM$  and / or the phase margin  $PM$  are/is negative, then the control system is **unstable**.

## 7.6. log magnitude versus phase plot

**Magnitude Plot:** In this plot, magnitude is represented in logarithmic values against logarithmic values of frequency.

For the transfer function  $G(j\omega)H(j\omega)$ , in order to express the magnitude in logarithmic values, we need to find,  $|G(j\omega)| = 20 \log_{10} |G(j\omega)|$  dB

And this magnitude in dB is plotted for  $\log_{10} \omega$ . This is represented in the general

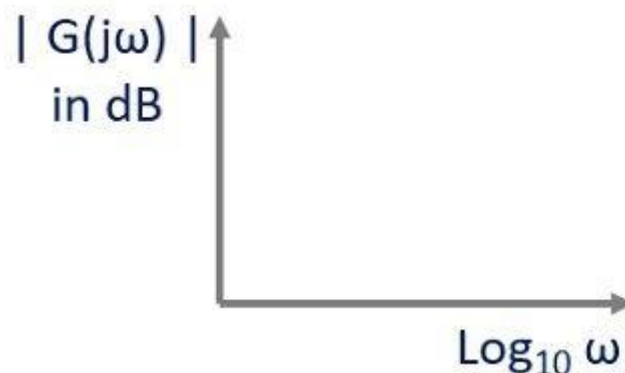

representation figure given below:

**2. Phase Angle Plot:** Here, the phase angle in degrees is sketched against logarithmic values of frequency.

Here, the angular value of  $G(j\omega)$  in degrees is sketched against  $\log_{10} \omega$ . The figure here represents the general representation of phase angle plot:

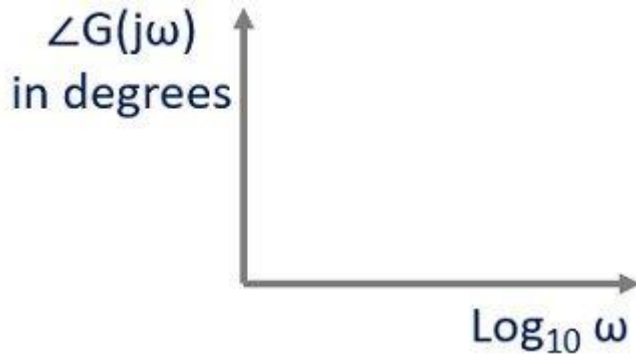

Bode Plot is also known as the logarithmic plot as it is sketched on the logarithmic scale and represents a wide range of variation in magnitude and phase angle with respect to frequency, separately. Thus, the bode plots are sketched on semi-log graph paper.

Also, as we can see that in both the plots the logarithmic value of frequency is scaled on the x-axis, so, x-axis can be kept common and both magnitude and phase angle plots can be drawn on the same log paper.

It is to be noted here that, suppose, we are having open-loop transfer function of the system  $G(j\omega)H(j\omega)$  and we have to determine the closed-loop stability by making use of frequency response of the open-loop system. Then, not simply  $G(j\omega)$  but magnitude and phase angle of  $G(j\omega)H(j\omega)$  is to be plotted against  $\log_{10} \omega$ .

### 7.7. Closed Loop Frequency Response

The Bode plot is generally constructed for an open loop transfer function of a system. In order to draw the Bode plot for a closed loop system, the transfer function has to be developed, and then decomposed into its poles and zeros. This process is tedious and cannot be carried out without the aid of a very powerful calculator or a computer.

With reference to the generic unity feedback system block diagram and its polar plot; the system transfer function is given by:

$$\frac{C(s)}{R(s)} = \frac{G(s)}{1 + G(s)}$$

The dashed line in the polar plot is the trace of the tip of the vector  $OA$  which represents the system. The length of the vector measure the magnitude of the system at a given frequency  $\omega$ , and the angle  $\phi$  represents the phase shift.

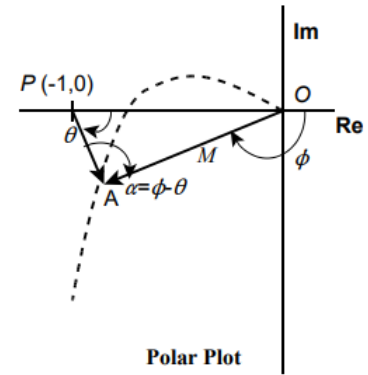
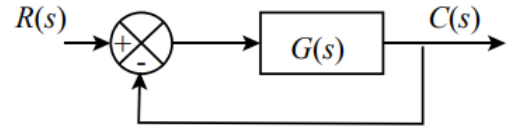

Consider the following non unity feedback system:

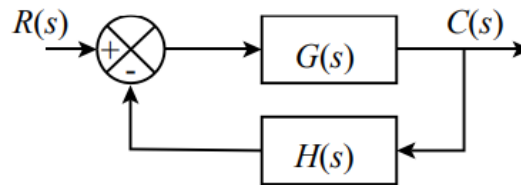

It can be transformed into the following system composed of a simple block cascaded to a unity feedback system:

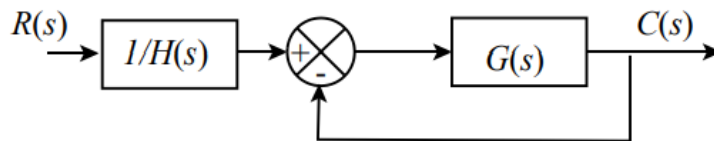

The frequency response can be then obtained using the additive feature of the Bode plots.

With reference to the polar plot;

$\overline{OA}$  represents  $G(j\omega)$

$\overline{OP}$  represents -1

But  $\overline{PA} = \overline{PO} + \overline{OA}$   
 $= 1 + G(j\omega)$

$$\therefore \frac{\overline{OA}}{\overline{PA}} = \frac{G(j\omega)}{1 + G(j\omega)}$$

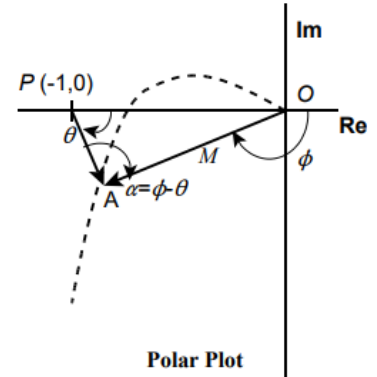

The phase shift angle of the closed loop system is the included angle between the vectors  $OA$  and  $PA$ , i.e.;

$$\alpha = \phi - \theta$$

## FREQUENCY RESPONSE ANALYSIS Closed Loop Constant Magnitude Loci

Since the open loop transfer function is a complex quantity that can be expressed as:

$$G(j\omega) = X + jY$$

It follows that the magnitude of the closed loop system can be expressed as follows:

$$\begin{aligned} M &= \frac{|G(j\omega)|}{|1 + G(j\omega)|} \\ &= \frac{|X + jY|}{|(1 + X) + jY|} \end{aligned}$$

---

$$\therefore M^2 = \frac{X^2 + Y^2}{(1 + X)^2 + Y^2}$$

## FREQUENCY RESPONSE ANALYSIS Closed Loop Constant Magnitude Loci

Expanding and collecting terms, the previous equation gives:

$$X^2(1 - M^2) - 2M^2X - M^2 + (1 - M^2)Y^2 = 0$$

For  $M=1$  the above equation reduces to;

For  $M=1$  the above equation reduces to;

$$X = -\frac{1}{2}$$

For  $M \neq 1$ , the equation can be written in the form:

$$X^2 + \frac{2M^2}{M^2 - 1}X + \frac{M^2}{M^2 - 1} + Y^2 = 0$$

---

## FREQUENCY RESPONSE ANALYSIS

### Closed Loop Constant Magnitude Loci

The preceding equation cannot be factored as it stands. However by adding;

$$\frac{M^2}{(M^2 - 1)^2}$$

to both sides and factoring gives:

$$\left( X + \frac{M^2}{M^2 - 1} \right)^2 + Y^2 = \frac{M^2}{(M^2 - 1)^2}$$

This is an equation of a circle with radius and center as follows:

$$\text{center: } \left( -\frac{M^2}{M^2 - 1}, 0 \right) \text{ and radius: } \frac{M}{M^2 - 1}$$

# FREQUENCY RESPONSE ANALYSIS

## Closed Loop Constant Magnitude Loci

A plot of the previous equation is shown below for different magnitudes  $M$ :

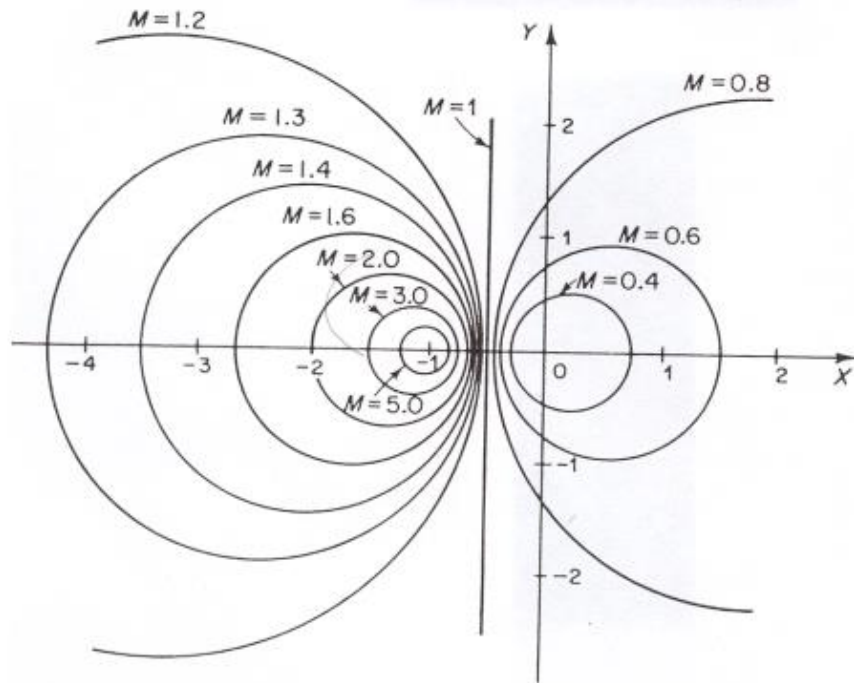

## FREQUENCY RESPONSE ANALYSIS

### Closed Loop Constant Phase Loci

The phase of the closed loop system can be expressed as follows:

$$\angle e^{j\alpha} = \left| \frac{X + jY}{1 + X + jY} \right|$$

$$\therefore \alpha = \tan^{-1} \frac{Y}{X} - \tan^{-1} \frac{Y}{1 + X}$$

Now let  $\alpha = N$ , then;

$$N = \tan \left[ \tan^{-1} \frac{Y}{X} - \tan^{-1} \frac{Y}{1 + X} \right]$$

#### Short questions and ans

1Q.what do you mean by frequency response?

It is defined as the steady state response of a system due to sinusoidal input

2Q.define bode plot?

A Bode plot is generally used in electrical engineering and control theory and is represented by a graph depicting the frequency responses of a particular system. It is an important tools used in linear time invariant systems (LTI systems) for showing its gain or the magnitude and the phase response with respect to different operating frequencies.

3Q.Define gain margin?

he greater the **Gain Margin** (GM), the greater the stability of the system. The gain margin refers to the amount of gain, which can be increased or decreased without making the system unstable. It is usually expressed as a magnitude in dB.

We can usually read the gain margin directly from the Bode plot (as shown in the diagram above). This is done by calculating the vertical distance between the magnitude curve (on the Bode magnitude plot) and the x-axis at the frequency where the Bode phase plot = 180°. This point is known as the **phase crossover frequency**.

4QDefine Phase margin?

The greater the **Phase Margin (PM)**, the greater will be the stability of the system. The phase margin refers to the amount of phase, which can be increased or decreased without making the system unstable. It is usually expressed as a phase in degrees.

Long questions

1. Explain close loop frequency response analysis?
2. Explain polar plot and its rule to construct polar plot?
3. Explain all pass minimum phase equation?

## Chapter-8

### Nyquist Plot

#### 8.1.principle of argument

The Nyquist stability criterion works on the **principle of argument**. It states that if there are  $P$  poles and  $Z$  zeros are enclosed by the 's' plane closed path, then the corresponding  $G(s)H(s)G(s)H(s)$  plane must encircle the origin  $P-Z$  times. So, we can write the number of encirclements  $N$  as,

$$N = P - Z$$

- If the enclosed 's' plane closed path contains only poles, then the direction of the encirclement in the  $G(s)H(s)G(s)H(s)$  plane will be opposite to the direction of the enclosed closed path in the 's' plane.
- If the enclosed 's' plane closed path contains only zeros, then the direction of the encirclement in the  $G(s)H(s)G(s)H(s)$  plane will be in the same direction as that of the enclosed closed path in the 's' plane.

Let us now apply the principle of argument to the entire right half of the 's' plane by selecting it as a closed path. This selected path is called the **Nyquist** contour.

We know that the closed loop control system is stable if all the poles of the closed loop transfer function are in the left half of the 's' plane. So, the poles of the closed loop transfer function are nothing but the roots of the characteristic equation. As the order of the characteristic equation increases, it is difficult to find the roots. So, let us correlate these roots of the characteristic equation as follows.

- The Poles of the characteristic equation are same as that of the poles of the open loop transfer function.
- The zeros of the characteristic equation are same as that of the poles of the closed loop transfer function.

We know that the open loop control system is stable if there is no open loop pole in the the right half of the 's' plane.

i.e.,  $P=0 \Rightarrow N = -Z$   
 $P=0 \Rightarrow N = -Z$

We know that the closed loop control system is stable if there is no closed loop pole in the right half of the 's' plane.

$$\text{i.e., } Z=0 \Rightarrow N=P$$

## 8.2. Nyquist stability criterion

**Nyquist stability criterion** states the number of encirclements about the critical point  $(1+j0)$  must be equal to the poles of characteristic equation, which is nothing but the poles of the open loop transfer function in the right half of the 's' plane. The shift in origin to  $(1+j0)$  gives the characteristic equation plane.

## 8.3. Nyquist stability criterion applied to inverse polar plot

(The Nyquist stability criterion can be applied equally well to inverse polar plots. The mathematical derivation of the Nyquist stability criterion for inverse polar plots is the same as that for direct polar plots.)

The inverse polar plot of  $G(j\omega)H(j\omega)$  is a graph of  $1/[G(j\omega)H(j\omega)]$  as a function of  $\omega$ . For example, if  $G(j\omega)H(j\omega)$  is

$$G(j\omega)H(j\omega) = \frac{j\omega T}{1 + j\omega T}$$

then

$$\frac{1}{G(j\omega)H(j\omega)} = \frac{1}{j\omega T} + 1$$

The inverse polar plot for  $\omega \geq 0$  is the lower half of the vertical line starting at the point  $(1,0)$  on the real axis.

The Nyquist stability criterion applied to inverse plots may be stated as follows: For a closed-loop system to be stable, the encirclement, if any, of the  $-1 j0$  point by the  $1/[G(s)H(s)]$  locus (as  $s$  moves along the Nyquist path) must be counterclockwise, and the number of such encirclements must be equal to the number of poles of  $1/[G(s)H(s)]$  [that is, the zeros of  $G(s)H(s)$ ] that lie in the right-half  $s$  plane. [The number of zeros of  $G(s)H(s)$  in the right-half  $s$  plane may be determined by use of the Routh stability criterion.]

If the open-loop transfer function  $G(s)H(s)$  has no zeros in the right-half  $s$  plane, then for a closed-loop system to be stable the number of encirclements of the  $-1 j0$  point by the  $1/[G(s)H(s)]$  locus must be zero.

Note that although the Nyquist stability criterion can be applied to inverse polar plots, if experimental frequency-response data are incorporated, counting the number of encirclements of the  $1/[G(s)H(s)]$  locus may be difficult because the phase shift corresponding to the infinite semicircular path in the  $s$  plane is difficult to measure. For example, if the open-loop transfer function  $G(s)H(s)$  involves transport lag such that

$$G(s)H(s) = \frac{Ke^{-j\omega L}}{s(Ts + 1)}$$

then the number of encirclements of the  $-1/j0$  point by the  $1/[G(s)H(s)]$  locus becomes infinite, and the Nyquist stability criterion cannot be applied to the inverse polar plot of such an open-loop transfer function.

In general, if experimental frequency-response data cannot be put into analytical form, both the  $G(j\omega)H(j\omega)$  and  $1/[G(j\omega)H(j\omega)]$  loci must be plotted. In addition, the number of right-half plane zeros of  $G(s)H(s)$  must be determined. It is more difficult to determine the right-half plane zeros of  $G(s)H(s)$  (in other words, to determine whether a given component is minimum phase) than it is to determine the right-half plane poles of  $G(s)H(s)$  (in other words, to determine whether the component is stable).

Depending on whether the data are graphical or analytical and whether non minimum-phase components are included, an appropriate stability test must be used for multiple-loop systems. If the data are given in analytical form or if mathematical expressions for all the components are known, the application of the Nyquist stability criterion to inverse polar plots causes no difficulty, and multiple-loop systems may be analyzed and designed in the inverse GH plane

#

#### 8.4. Effect of addition of poles and zeros to $G(S)H(S)$ on the shape of Niquist plot

- Typically, the Nyquist path should not go through any pole or zero. Hence, the Nyquist path should be slightly modified to avoid this situation.
- Nyquist path is altered by allowing a semi-circle detour with an infinitesimal radius around the origin.
- The small semi-circle is represented using magnitude and phase  $\epsilon e^{j\theta}$ .
  - Note that for type-1 systems,  $\lim_{s \rightarrow \epsilon e^{j\theta}} GH(s) = \frac{1}{\epsilon} e^{-j\theta}$
  - Note that for type-1 systems,  $\lim_{s \rightarrow \epsilon e^{j\theta}} GH(s) = \frac{1}{\epsilon^2} e^{-j2\theta}$
- Example  $G(s) = K/[s(1 + Ts)]$

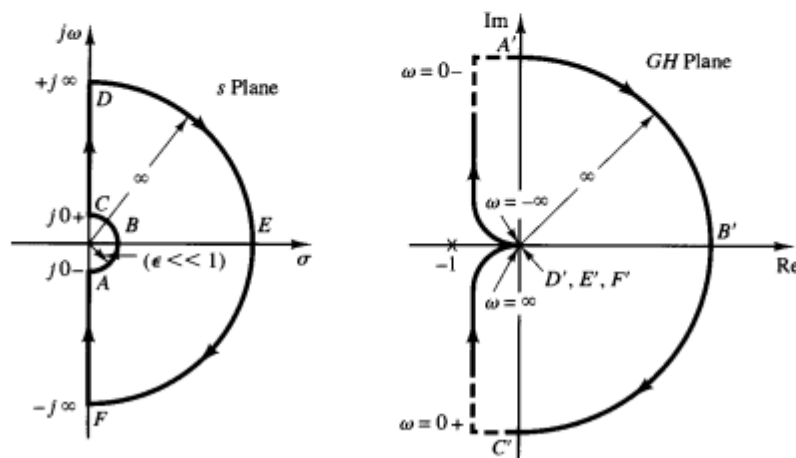

Figure 11: Modified Nyquist Path  $GH(s) = K/[s(1 + Ts)]$

- $P=0$ ,
- No encirclements form contour mapping  $N=0$ ,
- $Z=P+N=0 \Rightarrow$  the system is stable.

Example:  $G(s) = K/[s^2(1 + Ts)]$

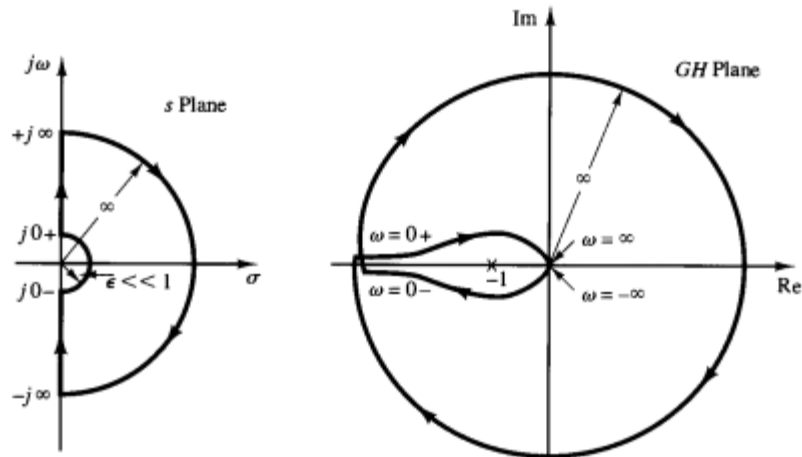

Figure 12: Modified Nyquist Path  $G(s) = K/[s^2(1 + Ts)]$

- $P=0$  for positive  $T$
- Two clockwise encirclements  $N=2$ ,
- $\therefore Z=N+P=2 \Rightarrow$  there exist two zeros for the characteristic equations in the RHP.
- Hence, the system is unstable.

### 8.5. Assessment of relative stability

We have introduced the Nyquist criterion for the absolute stability analysis of the system. Using the Nyquist criterion, it is also possible to find the relative stability of the system. By relative stability we mean how close the system is to instability, and we can improve the stability of the system. The degree or extent of the system is called relative stability. If the Nyquist polar plot is close to  $-1 + j0$  point, the system is on the verge of instability. The proximity to  $-1 + j0$  point is specified in terms of the following two quantities:

### 15.6.1 Gain Margin

The gain margin is defined as the reciprocal of the open-loop transfer function evaluated at the frequency  $\omega_{pc}$  at which the phase angle is  $-180^\circ$ .

$$\text{Gain margin} = \frac{1}{|G(j\omega)H(j\omega)|}$$

$$\phi = \angle G(j\omega)H(j\omega)$$

The frequency  $\omega_{pc}$  is known as the phase crossover frequency at which the polar plot crosses the negative real axis. Gain margin measures the relative distance between the  $-1 + j0$  point and the  $G(j\omega)H(j\omega)$  plot.

Depending upon the phase crossover point  $X$  shown in Fig. 15.8, we set the gain. If the point  $X$  is too near the  $-1 + j0$  point, we can decide how much to reduce the gain and if the point  $X$  is too far from the  $-1 + j0$  point, we can decide how much to increase the gain.

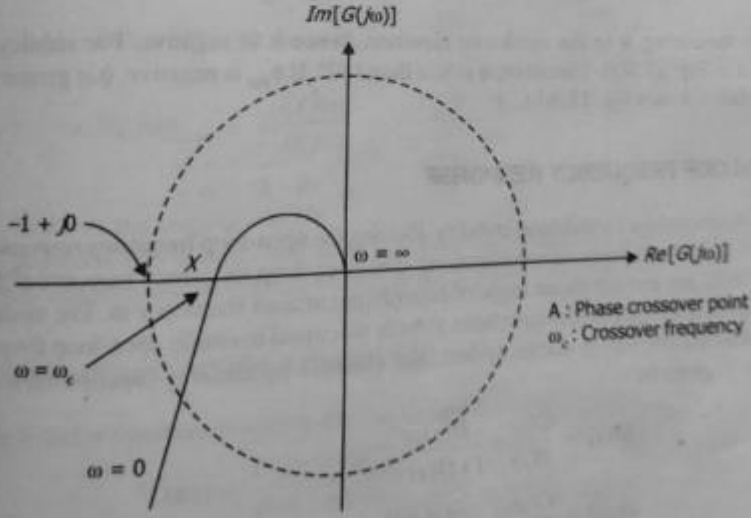

Fig. 15.8 Gain margin

### 15.6.2 Phase Margin

Gain margin alone is not sufficient to indicate the relative stability of a system. Another parameter, phase margin, supplements the gain margin. A rigorous definition of the phase margin ( $\phi_{PM}$ ) is the angle by which the polar plot is rotated to cause it to pass through  $(-1, j0)$  point.  $\phi_{PM}$  is the angle between the positive real axis and the radius vector joining the origin to the gain crossover frequency ( $\omega_{gc}$ ). The radius

vector is  $|G(j\omega)H(j\omega)|$ . The gain crossover frequency is the frequency at which  $|G(j\omega)H(j\omega)| = 1$ , i.e., the intersection of the polar plot and the  $(-1, j0)$  circle.

$$\text{Phase margin} = 180^\circ + \phi$$

where

$$\phi = \angle G(j\omega)H(j\omega) \text{ and } |G(j\omega)H(j\omega)| = 1.$$

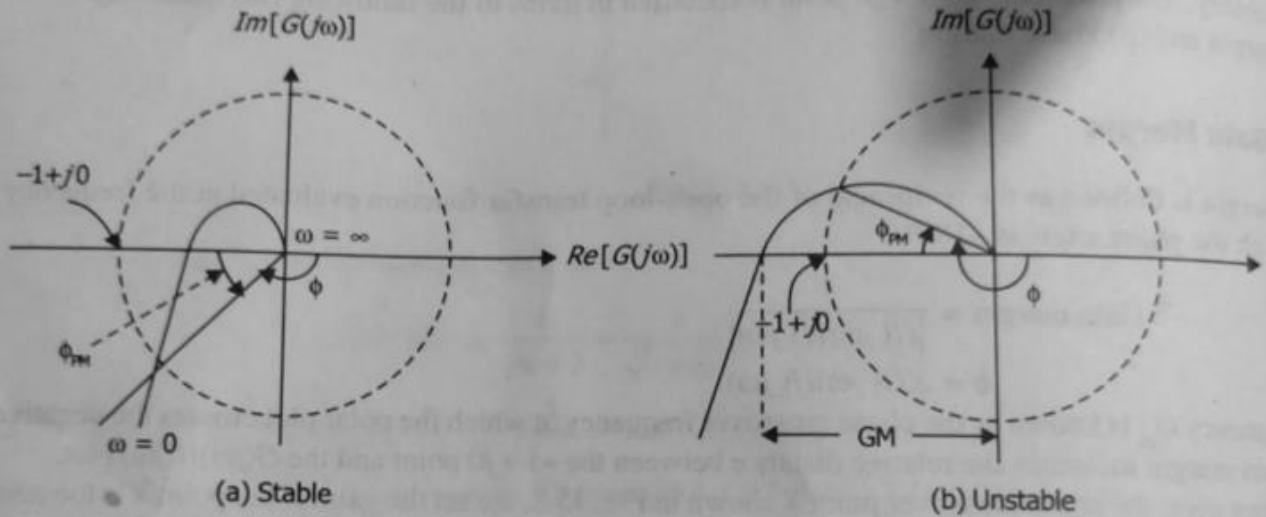

Fig. 15.9 Phase margin

Here we are measuring  $\phi$  in the clockwise direction, hence it is negative. For stability,  $\phi$  is positive as shown in Fig. 15.9(a). Therefore,  $\phi$  is less than  $180^\circ$ . If  $\phi_{PM}$  is negative,  $\phi$  is greater than  $180^\circ$  and the system is unstable shown Fig. 15.9(b).

## 8.6.Constant M&N circle

Constant magnitude loci that are M-circles and constant phase angle loci that are N-circles are the fundamental components

- The constant M and constant N circles in  $G(j\omega)$  plane can be used for the analysis and design of control systems.
- However the constant M and constant N circles in gain phase plane are prepared for system design and analysis as these plots supply information with fewer manipulations.

Gain phase plane is the graph having gain in decibel along the ordinate (vertical axis) and phase angle along the abscissa (horizontal axis).

- The M and N circles of  $G(j\omega)$  in the gain phase plane are transformed into M and N contours in rectangular coordinates.
- A point on the constant M loci in  $G(j\omega)$  plane is transferred to gain phase plane by drawing the vector directed from the origin of  $G(j\omega)$  plane to a particular point on M circle and then measuring the length in db and angle in degree.

The critical point in  $G(j\omega)$  plane corresponds to the point of zero decibel and  $-180^\circ$  in the gain phase plane. Plot of M and N circles in gain phase plane is known as Nichols chart /plot.

The Nichols plot is named after the American engineer N.B Nichols who formulated this plot.

Compensators can be designed using Nichols plot.

Nichols plot technique is however also used in designing of dc motor. This is used in signal processing and control design.

Nyquist plot in complex plane shows how phase of transfer function and frequency variation of magnitude are related.

- Angle of positive real axis determines the phase and distance from origin of complex plane determines the gain.

Advantages

- Gain and phase margin can be determined easily and also graphically.
- Closed loop frequency response is obtained from open loop frequency response.
- Gain of the system can be adjusted to suitable values.
- Nichols chart provides frequency domain specifications.

Disadvantage

- Using Nichols plot small changes in gain cannot be encountered easily.

# Constant M & N Circles

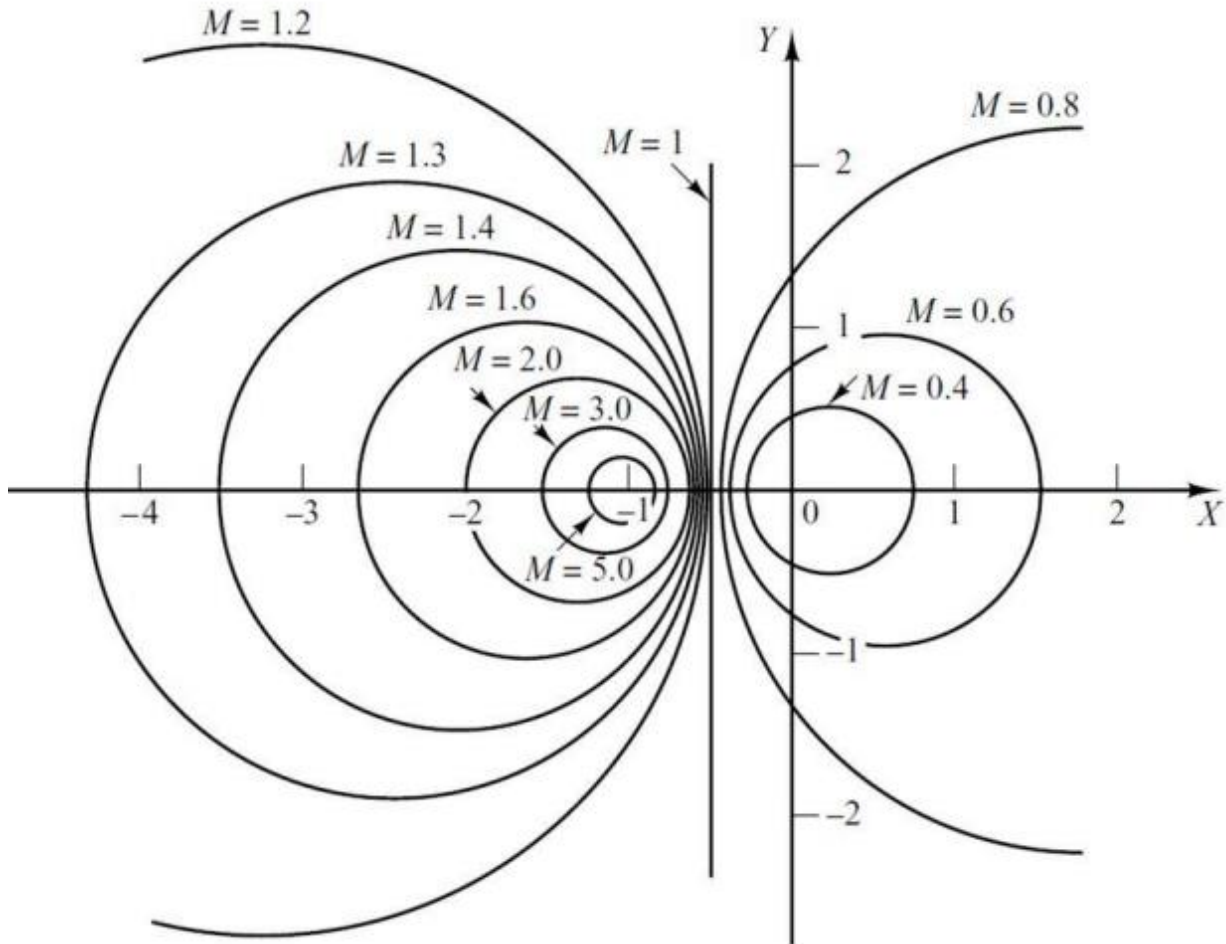

8.7. Nicholas Chart

## 15.8 NICHOL'S CHART

It is possible to obtain the frequency response by sketching the magnitude in dB against the phase angle for various frequencies. The plot obtained is called gain-phase plot or logmagnitude versus phase plot. Fig. 15.13 shows such a gain-phase plot for  $G(j\omega) = 1/(1+j\omega T)$ , i.e.,  $G(s) = 1/(1+sT)$ .

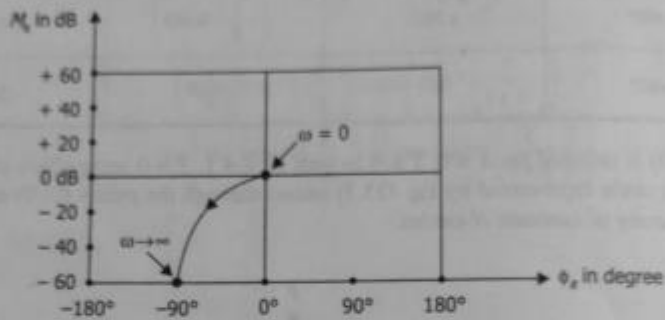

Fig. 15.13 Gain-phase plot for  $G(j\omega)$

After transferring the constant magnitude loci ( $M$  circles) and constant phase angle loci ( $N$  circles) to the gain phase plot, the resultant chart is known as Nichol's chart.

If we superimpose the gain-phase plot of an open-loop transfer function on Nichol's chart, we get very easily the closed-loop frequency response. The magnitude is expressed in dB while the phase angle is in degrees. Nichol's chart gives the points of intersection of the gain-phase plot of an open-loop transfer function, which are symmetrical about the  $-180^\circ$  axis. The  $M$  and  $N$  loci also repeat for every  $360^\circ$ . Again symmetry exists at every  $180^\circ$  interval. The  $M$  loci are centered about the critical point  $(0 \text{ dB}, -180^\circ)$ . Figure 5.14 shows Nichol's chart.

Nichol's chart is used for the following:

- (1) The complete closed-loop frequency response can be determined.
- (2) The value of resonant peak  $M_r$  or closed-loop system, with given  $G(j\omega)$  can be obtained.
- (3) The frequency  $\omega_r$ , corresponding to the  $M_r$  for the closed-loop system can be also obtained.
- (4) If  $M_r$  and  $\omega_r$  are known, other frequency and time domain specifications can also be calculated.
- (5) The 3 dB bandwidth of the closed-loop system can be determined.
- (6) For the given  $M_r$ , it is possible to design the value of  $K$ .
- (7) For designing the compensating networks which are useful to meet more than one specifications for the closed-loop system.

## Shot questions

1. Define encircled?

Ans-if point is found to be inside the path. The point is said to be encircled by the close path

2. Define analytic function?

Ans-A function is said to be analytic at a point in a plane .if its value and derivative have finite existence at that point.

3. what do you mean by Nyquist criterion?

Ans-It focus on relative stability of the system. It is possible to determine the stability of a close loop pole from an open loop pole without knowing the roots of close loop system. A Niquist plot is based on a polar plot.

## Long Questions

**1.** For  $G(s)H(s)=1/s(s+2)$  draw the Niquist plot and decide stability?

**2.** For  $G(s)H(s)=1/s^2(s+2)$  sketch the Nyquist plot and determine the stability of the system?